

+BATT POSITIVE POLE OF POWER SUPPLY  
 -BATT NEGATIVE POLE OF POWER SUPPLY  
 PMP WINDSCREEN WASHING PUMP COMMAND  
 N.C. NO CONNECTION  
 S NORMAL SPEED MOTOR CONNECTION  
 F FAST SPEED MOTOR CONNECTION  
 -M NEGATIVE POLE OF MOTOR  
 P WIPER SELF-PARKING SWITCH INPUT

**CONTROLLED**  
 26 July 2011 14:01:41

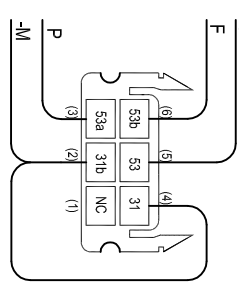

DETAIL OF  
 BOSCH HARNESS  
 CONNECTOR  
 (REAR VIEW)

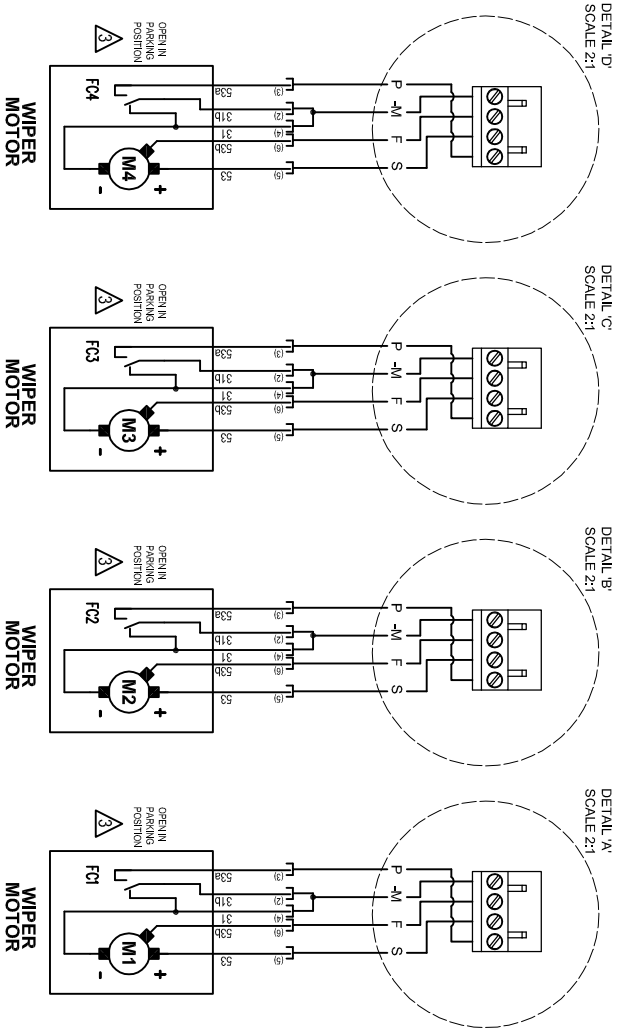
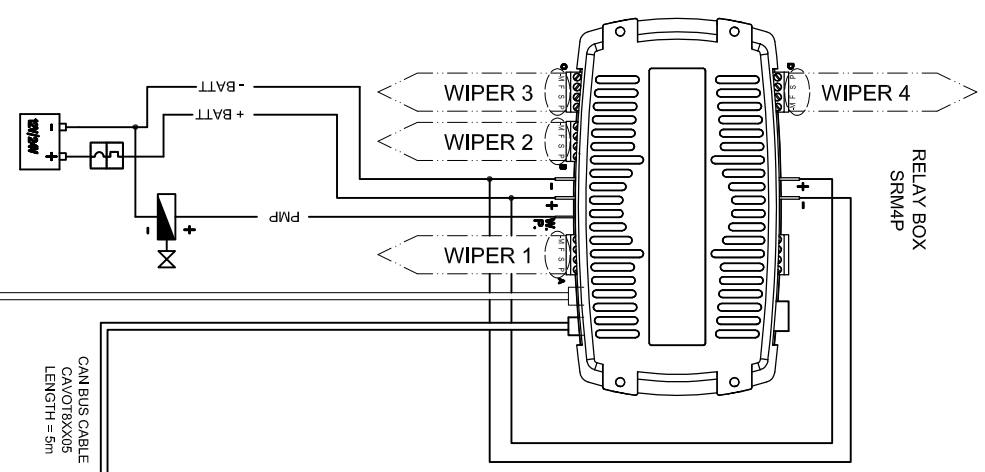

TO OPTIONAL  
 CONTROL UNIT  
 CP4P2 OR TO CAN  
 BUS NETWORK

Issue	Changed/Mod No.	Date	Name
1.	DRAWING CREATED & VALIDATED	03.05.05	A.P.G
2.	S975 - NEW GENERATION PARTS	30.06.11	D.G.H
3.	S1217 - WIRING ROUTE UPDATED	26.07.11	D.G.H

Drawing Log No.	Drawn by	Approved by	Drawing Date
S975	D.G.H		30/06/2011

**INTERCONNECTION DIAGRAM**

CT74 SERIES CONTROLLER

**HEPWORTH MARINE INTERNATIONAL**

A Division of B. Hepworth  
 B. Hepworth & Co. Ltd  
 2-4 Merse Road North Moons Mead  
 Redditch Worcestershire B98 9HL  
 tel 01527 63057 fax 01527 66836

**GENERAL TOLERANCES**

unless otherwise stated  
 Dimension - No decimal place ± 1  
 Dimension - One decimal place ± 0.5  
 Dimension - Two decimal places ± 0.25  
 Dimension - Three decimal places ± 0.125  
 Dimension - Four decimal places ± 0.0625  
 Angular Dimension ± 1°

All dimensions are in mm unless otherwise stated

B. Hepworth & Co. Ltd. (the Owner) holds intellectual property rights in the article shown. This drawing and the article may not be copied in any form without prior written permission of the Owner.  
 © B. Hepworth & Co. Ltd., 2010

**HEPWORTH**  
 INTERNATIONAL  
 B. Hepworth & Co. Ltd  
 2-4 Merse Road North Moons Mead  
 Redditch Worcestershire B98 9HL  
 tel 01527 63057 fax 01527 66836

HE0445-CT24/SRM4P  
 Issue No.

ISSUE No.

NOTE CRITICAL DIMENSIONS MARKED THUS **CD**  
 SIGNIFICANT DETAILS MARKED THUS **SD**

Mail. Type -  
 Mail. Part No. -  
 Mail. Size -  
 Finish 1 - REMOVE SHARP EDGES  
 Finish 2 -  
 Other info -

**CONTROLLED** Issue Date - 26/07/2011

3RD ANGLE



DO NOT SCALE

IF IN DOUBT ASK

HE0445-CT24/SRM4P

3