



B. HEPWORTH
AND COMPANY LIMITED

*...performance wiper
systems...*

INSTALLATION AND MAINTENANCE
INSTRUCTIONS FOR THE
30NM COMPACT
SINGLE STATION
WINDSCREEN WIPER SYSTEM

CONTENTS

GENERAL INFORMATION AND SAFETY SUMMARY	4
SAFETY PRECAUTIONS	4
INTRODUCTION	4
VARI-ARC LEVER SETTINGS	4
ABBREVIATIONS AND DEFINITIONS	4
DESCRIPTION OF WIPER SYSTEM	5
WIPER MOTOR ASSEMBLY – OLD STYLE	5
WIPER MOTOR ASSEMBLY – NEW STYLE	5
EXPLODED VIEW OF LINKAGE	7
ELECTRICAL CONNECTIONS.....	7
WIPER ARM ASSEMBLY – PANTOGRAPH	7
WIPER ARM ASSEMBLY – PENDULUM	8
INSTALLATION INSTRUCTIONS.....	9
FITTING THE WIPER UNIT.....	12
FITTING THE WIPER BLADE.....	13
MUST BE AT TOP	13
FITTING THE WIPER ARM ASSEMBLY	14
VARI ARC UNITS – ARC ADJUSTMENT	16
ADJUSTING THE WIPER BLADE ANGLE	17
TROUBLESHOOTING	18
INTRODUCTION	18
SAFETY PRECAUTIONS	18
TROUBLESHOOTING PROCEDURES	18
TROUBLESHOOTING TABLE.....	18
TROUBLESHOOTING TABLE – CONTINUED.....	19
MAINTENANCE – TABLE.....	20
INTRODUCTION	20
SAFETY PRECAUTIONS	20
SCHEDULED MAINTENANCE ACTION CHECK	20
MAINTENANCE TABLE.....	20
MAINTENANCE TABLE – CONTINUED.....	21
HOW TO CHECK FOR WEAR ON THE ROD END	21
MAINTENANCE INSTRUCTIONS	22
TO REPLACE THE WIPER BLADE	23
TO REPLACE THE WIPER ARM.....	24
TO REPLACE THE 24V DRIVE CRANK/DOUBLE BEARING ASSEMBLY	25
TO REPLACE THE 12V DRIVE CRANK/DOUBLE BEARING ASSEMBLY	26
TO REPLACE THE LEVER/LINER/SPINDLE SUB ASSEMBLY.....	27
CONTROLLER INSTALLATION INSTRUCTIONS.....	28
12V/24V TOGGLE SWITCH – WIRING & SIZES.....	29
12V/24V TOGGLE SWITCH – OPERATION.....	29
12V/24V ROTARY SWITCH – WIRING & SIZES.....	31
12V/24V ROTARY SWITCH – OPERATION.....	32
12V OR 24V MULTI-SWITCH – WIRING & SIZES	33
12V OR 24V MULTI-SWITCH – OPERATION	34

EXTERNAL FITTINGS – LINKAGE..... 35
EXTERNAL FITTINGS – ARM..... 36

GENERAL INFORMATION AND SAFETY SUMMARY

As we will have no influence on the installation of complete windscreen wiper systems if installation is to be carried out by the customer, we are unable to accept liability for installation errors.

If you require any additional information or any special problems arise which the installation/maintenance instructions do not treat in sufficient detail please contact Customer Service at B. Hepworth and Co Ltd directly.

Safety Precautions

CAUTION! BEWARE OF INJURY!

BEFORE WORKING ON THE WIPER SYSTEM, OBSERVE THE FOLLOWING REMARKS WITHOUT FAIL!

Most wiper motors have a park setting, which permits them to default to the parked position if connected to the vehicle electrical system, even when the wiper is switched off. **FOR THIS REASON, AT THIS POINT IN TIME, NEITHER MAY THE WIPER ARM BE MOUNTED, NOR MAY ANY PERSON HAVE HANDS, FINGERS, ETC ANYWHERE NEAR THE WIPER SYSTEM.** Even small wiper motors can neither be braked nor stopped by hand.

NEVER REACH INTO THE AREA OF THE ROD LINKAGE WHEN THE SYSTEM IS RUNNING!

When putting into service (i.e. when connecting the wiper motor to the vehicle electrical system, even if the wiper switch is in the 0 position), never leave any loose items such as screwdrivers in the area of the wiper system, as flying objects could lead to injury.

Please ensure the equipment is handled with care. Do not drop or bang the equipment down on a hard surface taking extra care around the area where the motor shaft is situated. Do not hammer the motor shaft when installing the equipment, as this will cause the motor gear plate to deform causing premature failure of the unit.

Introduction

The Windscreen Wiper system utilised is detailed on the following pages. The primary components that form the Windscreen Wiper System are the wiper motor linkage, the wiper arm assemblies and the wiper blades.

Vari-Arc Lever Settings

IMPORTANT

Vari-arc levers which have been factory set will be torqued and paint marked. Do not adjust. Unpainted lever nuts must be torque tightened M8 = 20Nm, prior to the unit being fitted.

Where internal fixing screws and/or nuts are factory set and paint marked, leave untouched unless required to be changed or paint mark is damaged.

Abbreviations and Definitions

<i>Abbreviation</i>	<i>Definition</i>
Assy	Assembly
Brk	Bracket
D. Crk	Drive Crank

<i>Abbreviation</i>	<i>Definition</i>
LH	Left Hand
RH	Right Hand
S.A.	Sub Assembly

DESCRIPTION OF WIPER SYSTEM

The wiper motor and bracket is shown in Figures 1, 2 & 3. The electric wiper motor forms the central part of the windshield wiper system. The motor is mounted on a fabricated mild steel bracket which is polyester powder coated to prevent corrosion. The motor is connected electrically by means of a multi-pin connector. (Ref Figure 4.)

The drive lever is secured to the wiper motor shaft and connected through a tie bar, to the spindle lever assembly. These components transfer the motor shaft rotation to the wiper arm assemblies.

The drive mechanism provided transfers the rotary output from the motor; to a reciprocating motion of the spindles, this mechanism is zinc plated and is sized to give the correct angle of arc for the windscreen wiper arm being driven.

The Spindles that drive the wiper arms pass through the bulkhead, connecting the drive mechanism to the wiper arm; these are manufactured from stainless steel, to prevent corrosion. The spindles are driven from the main drive crank by connecting tie bars which distributes the load evenly between the arms of the wiper arm thus reduces the load on the individual interfaces between the wiper arm and the spindles.

Wiper Motor Assembly – Old Style

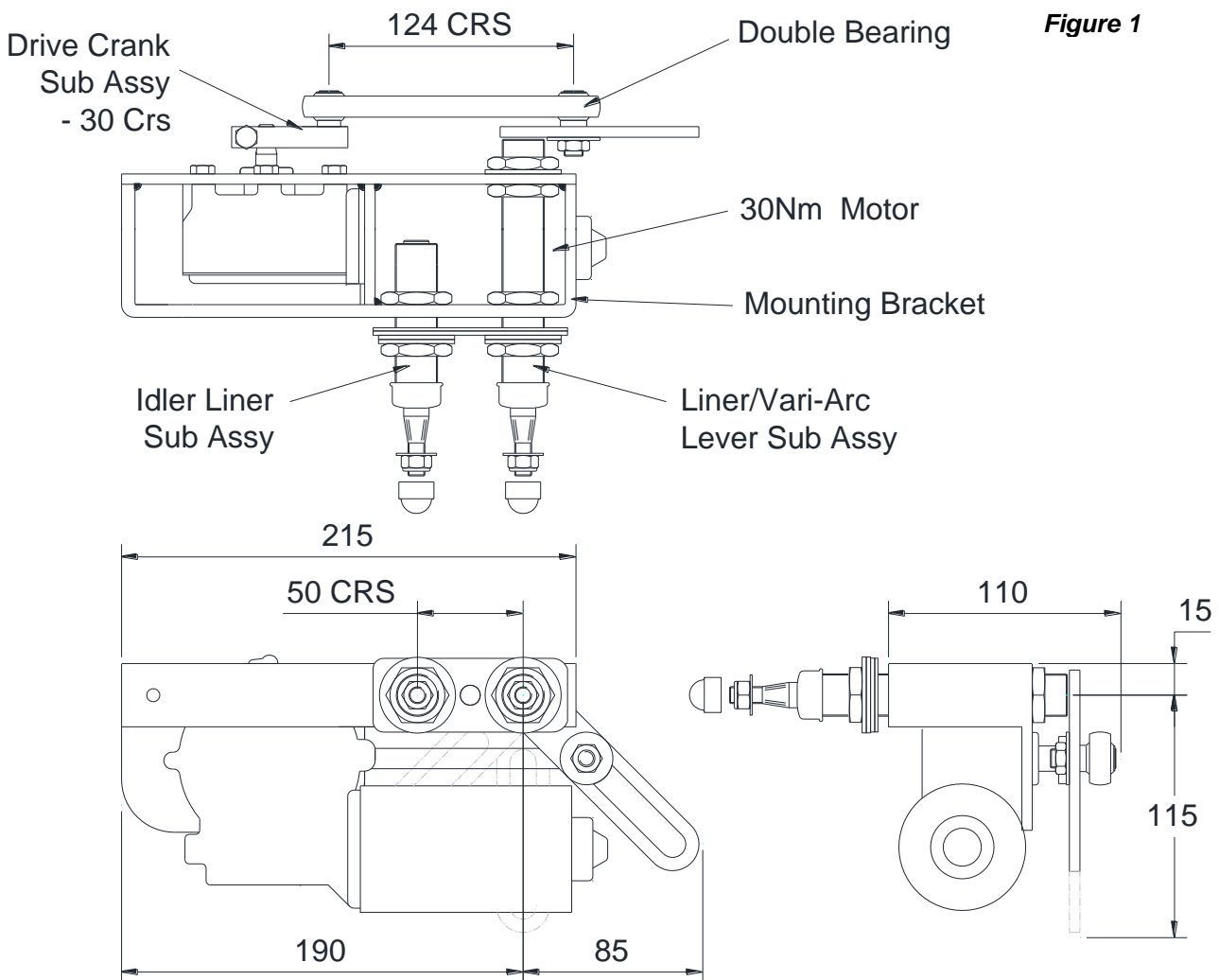

Wiper Motor Assembly – New Style

Figure 2

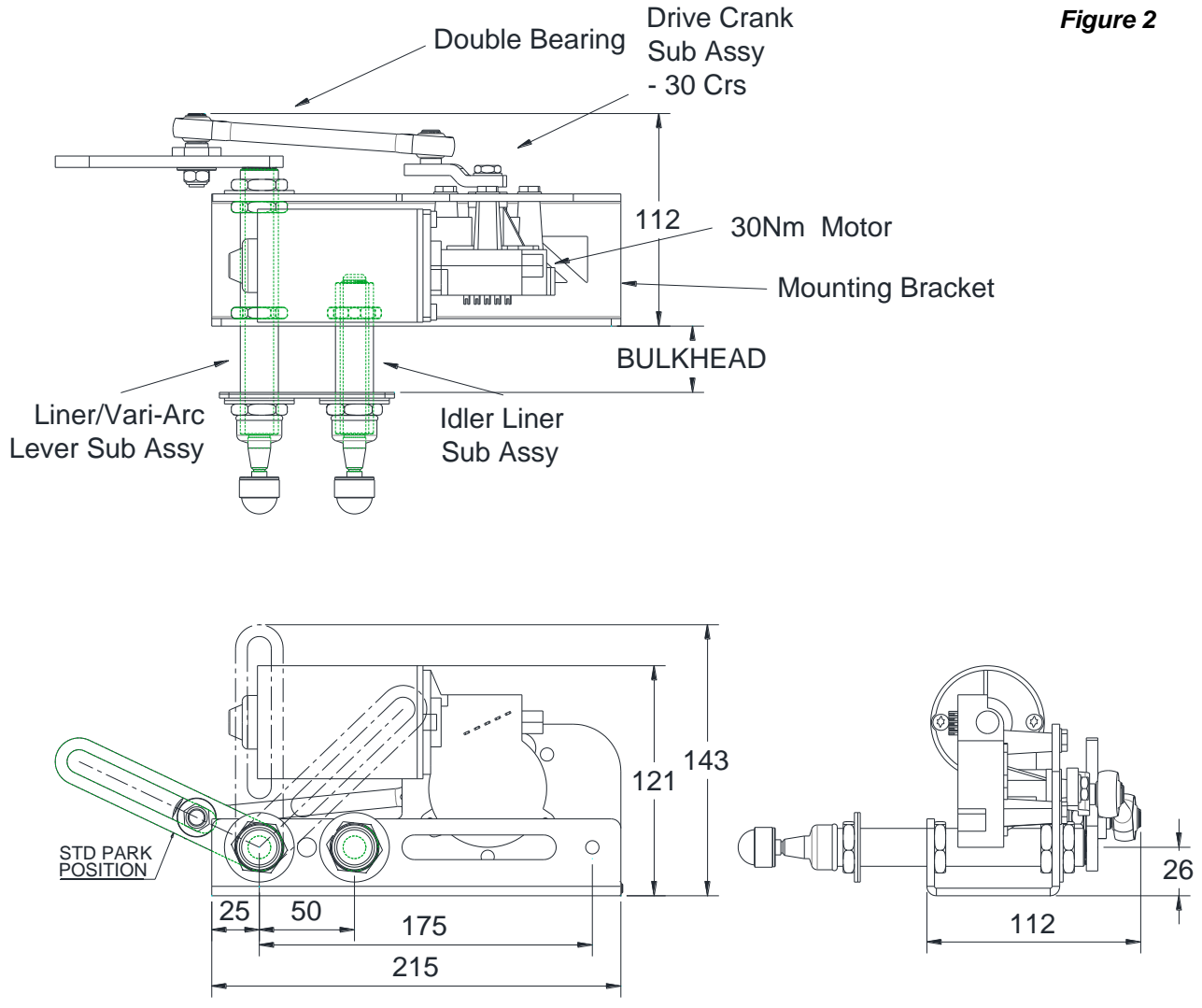

EXPLODED VIEW OF LINKAGE

BRACKET MAY LOOK DIFFERENT
DEPENDANT ON VERSION SUPPLIED

Figure 3

DETAIL OF
OPPOSITE
HAND
PARKING

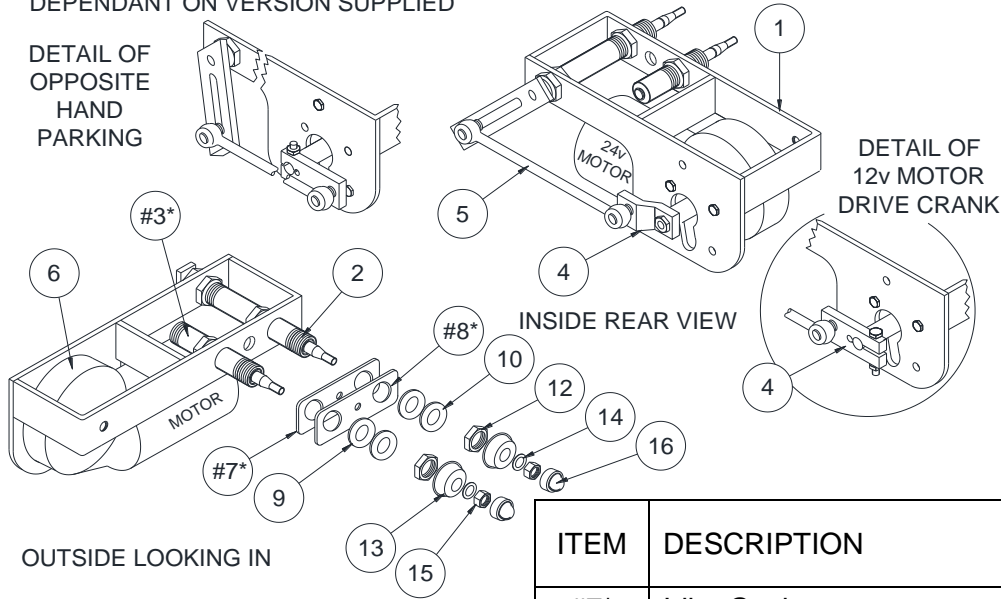

ITEM	DESCRIPTION	QTY
1	Motor Mounting Bracket	1
2	Liner V.Arc Lever Sub Assy	1
#3*	Idler Liner Sub Assy (Panto Only)	1
4	Drive Crank Sub Assy 30 Crs	1
5	Double Bearing – 124 Crs	1
6	30Nm (IER) Motor	1

ITEM	DESCRIPTION	QTY PANTO	QTY PEND
#7*	Idler Gasket (Panto Only)	1	--
#8*	Idler Plate (Panto Only)	1	--
9	20mm Washer - Neoprene	2	1
10	20mm Washer – Flat	2	1
12	M20 Hex. Nut	2	1
13	20mm Weather Cap	2	1
14	8mm Washer - Flat	2	1
15	M8 Nylock Nut	2	1
16	8mm Nut Weather Cap	2	1

Electrical Connections

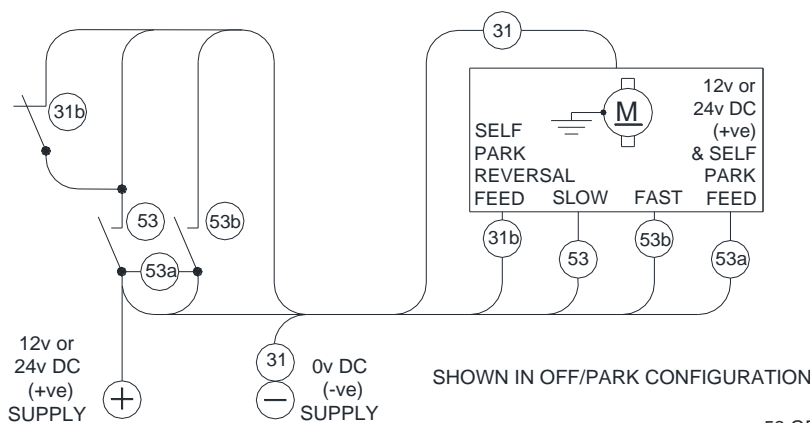
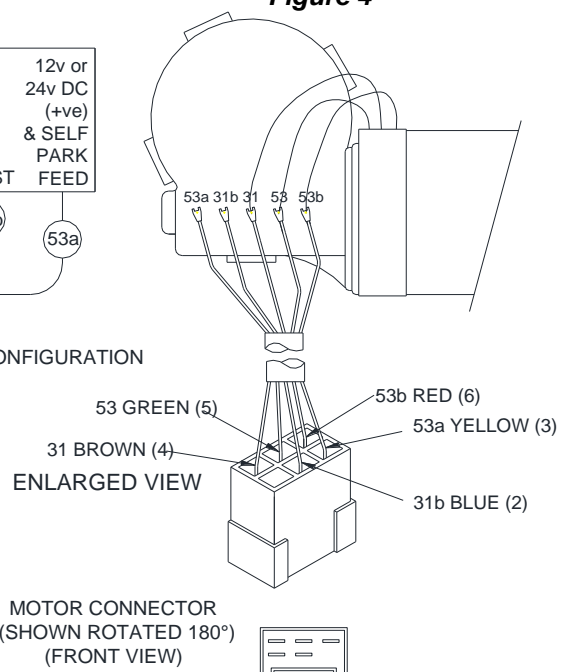

Figure 4



WIRING CONNECTION CODE		
31	Brown	0v DC (-ve) Supply
53	Green	Slow Speed
53b	Red	Fast Speed
53a	Yellow	24v DC (+ve) Supply & Self Park
31b	Blue	Self Park – Reversal Speed

Wiper Arm Assembly – Pantograph

The wiper arm is manufactured from stainless steel and is polyester powder coated to prevent corrosion and to be of good appearance.

The wiper arm is shown below. One wiper arm assembly is used on each unit. The wiper arm assembly mounts directly onto the spindles protruding through the bulkhead. The wiper arm is secured to the spindles via a series of nuts and washers.

Note: In some cases the Arm may have a forward crank to aid wiping.

The blade is secured to the arm assembly using the blade clip arrangement on the arm and blade retaining screw and nut.

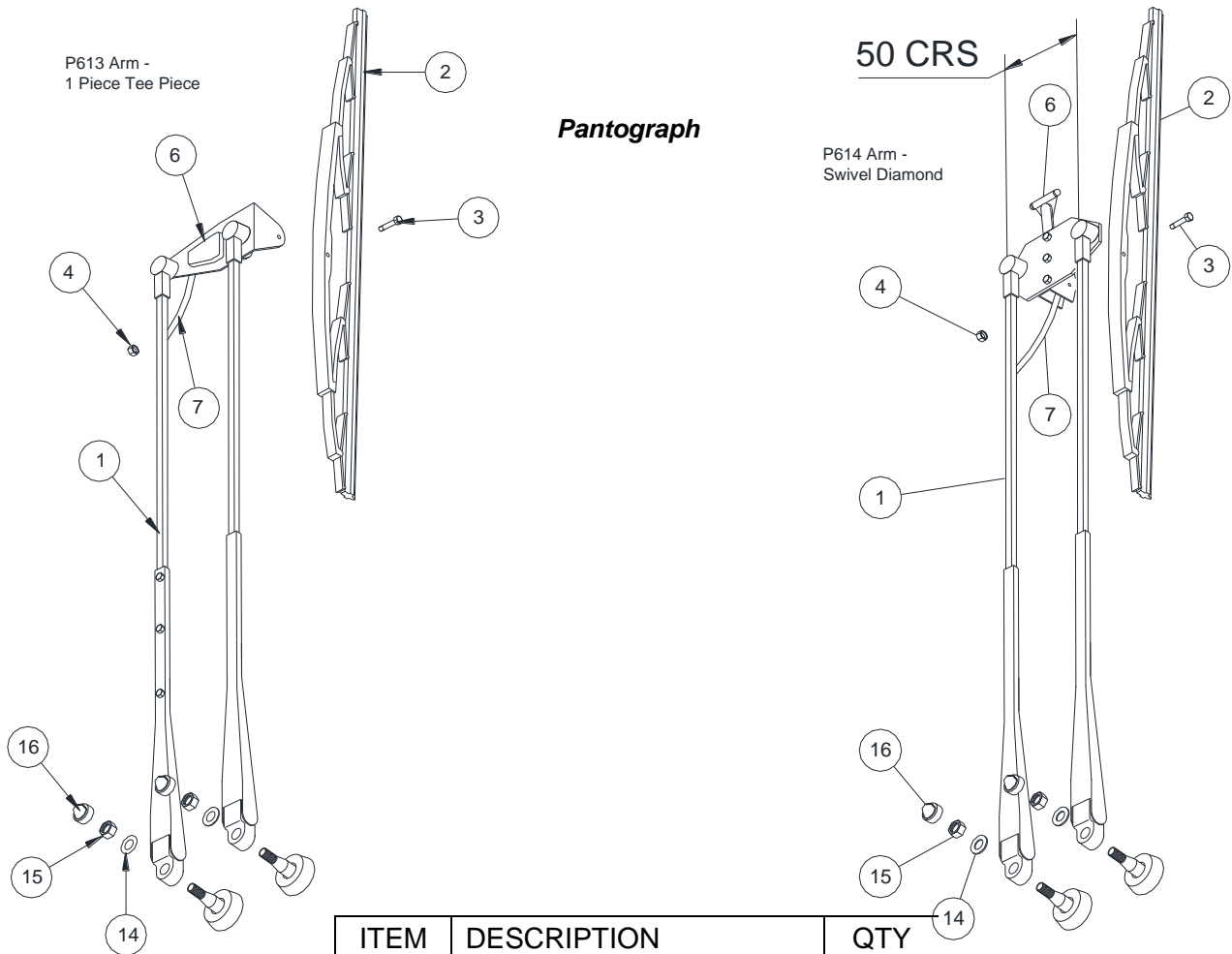

ITEM	DESCRIPTION	QTY
1	P613 Arm (<i>Channel Section</i>)	1
	P614 Arm (<i>Channel Section</i>)	1
2	Articulated Curved Blade	1
3	Blade Retaining Screw	1
4	Nylock Nut	1
6	Wash Jet Assy	1
7	Ecoprene Wash Tube	Metres

The Following Items are On The Linkage

14	8mm Washer - Flat	2
15	M8 Nylock Nut	2
16	8mm Nut Weather Cap	2

Wiper Arm Assembly – Pendulum

The wiper arm is manufactured from stainless steel and is polyester powder coated to prevent corrosion and to be of good appearance.

The wiper arm is shown below. One wiper arm assembly is used on each unit. The wiper arm assembly mounts directly onto the spindle protruding through the bulkhead. The wiper arm is secured to the spindle via a series of nuts and washers.

Note: In some cases the Arm may have a sideways crank to aid wiping (see details below.)

The blade is secured to the arm assembly using the blade clip arrangement on the arm and blade retaining screw and nut.

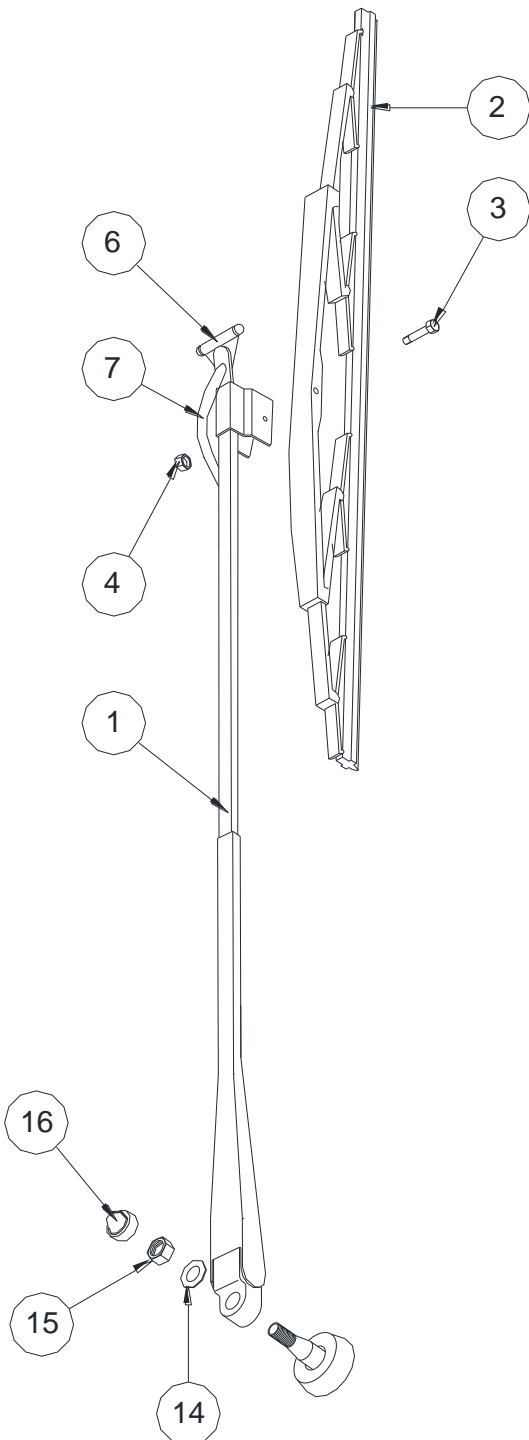

Pendulum Straight and Cranked

RIGHT HAND LEFT HAND
CRANK 5° - 25° CRANK 5° - 25°

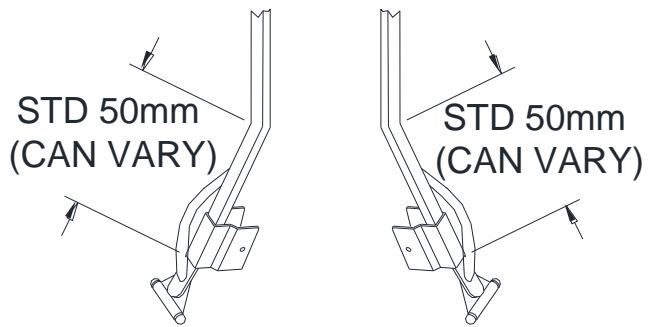

ITEM	DESCRIPTION	QTY
1	F63 Arm (<i>Straight-Channel Section</i>)	1
2	Articulated Curved Blade	1
3	Blade Retaining Screw	1
4	Nylock Nut	1
6	Wash Jet Assy	1
7	Ecoprene Wash Tube	Metres

The Following Items are On The Linkage

14	8mm Washer - Flat	1
15	M8 Nylock Nut	1
16	8mm Nut Weather Cap	1

INSTALLATION INSTRUCTIONS

NOTE

Retain all items removed in a safe place, as they will be required on reassembly.

Any item to be discarded must be done in accordance to vessels manufacturer described task guidelines

If you experience any difficulty in the fitting of any of the units/components, please do not hesitate to contact Customer Service at B. Hepworth & Co. for advice.

Use the drawings for reference.

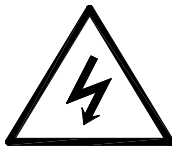

WARNING:

Isolate the electrical supply before commencing any fitting work on any part of the wiper system.

DRILLING DIAGRAM - FOR 30Nm COMPACT UNITS

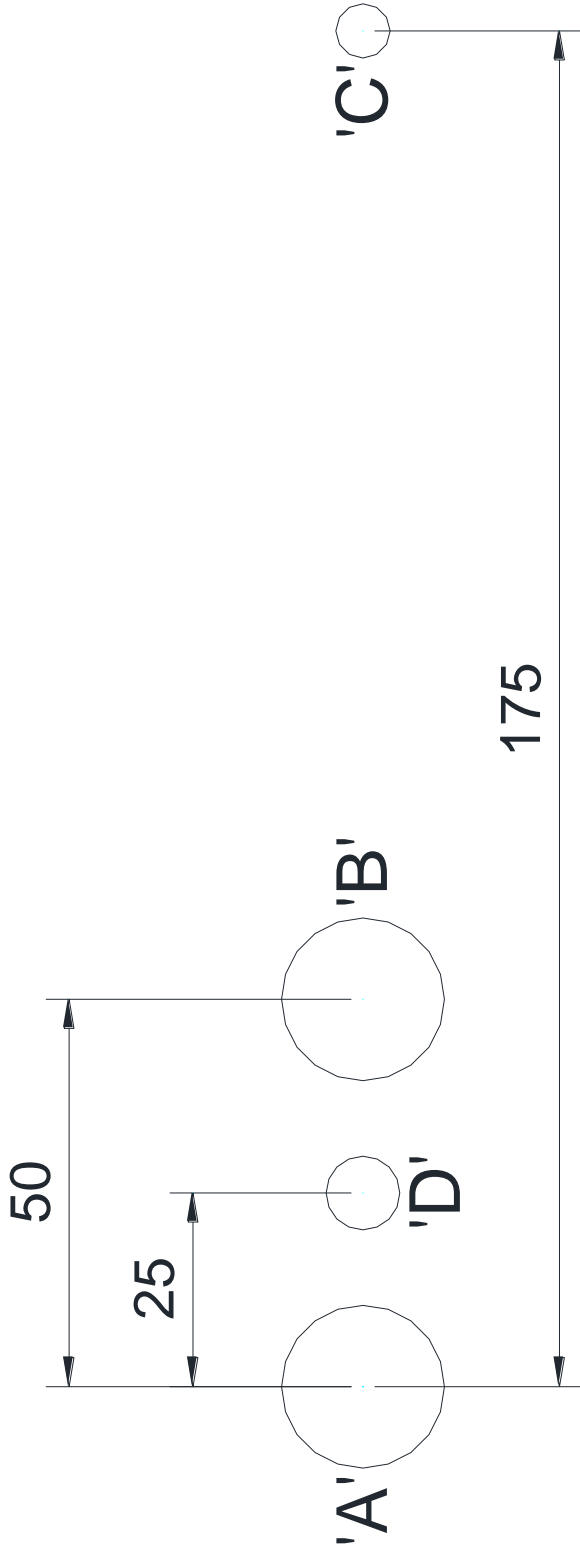

FOR PANTOGRAPH SYSTEMS

Drill holes 'A' and 'B' at Ø24mm

Drill hole 'C' at Ø7mm

Drill hole 'D' at Ø9mm

FOR PENDULUM SYSTEMS

Drill hole 'A' at Ø24mm

Drill hole 'C' at Ø7mm

(NOTE Hole 'D' - Only required if bulkhead connector is mounted through brkt)

FITTING THE WIPER UNIT

IMPORTANT

Vari-arc levers which have been factory set will be torqued and paint marked. Do not adjust. Unpainted lever nuts must be torque tightened M8 = 20Nm, prior to the unit being fitted.

Ref Figure – Drilling Diagram

When the spindle positions have been drilled in the bulkhead, the following procedures apply.

Ref Figure – Exploded Diagram

On all units –

1. Remove from each spindle one weather cap (16), one M8 nut (15), one washer – flat (14)
2. Remove from each liner, one weather cap (13), one M20 nuts (12), one washer – flat (10), and one washer – neoprene (9)

On Pantograph units only –

3. Remove idler plate (8) and finally idler gasket (7)

NOTE the Motor Unit is MOUNTED from INSIDE the Bulkhead.

4. Fit motor unit and fix in place through predrilled mounting holes (*Fixing bolts not supplied*)
5. *Externally* – ENSURE a proprietary sealant (*Not supplied*) is used around all points of entry through bulkhead.

On Pantograph units only –

6. *Fit following items* – one idler gasket (7) and one idler plate (8) over both liners, next to bulkhead.

On all units –

7. *Fit following items* – Onto each liner, one washer – neoprene (9), one washer – flat (10), one M20 nut (12)
Torque M20 = 25Nm (on Liner Nut – Metal Structure)
8. Fit onto each liner, one M20 weather cap (13), ensuring that it sits tightly around spindle shaft.
9. *Internally* – Wire motor to vessels electrics via switch/controller (*May or/may not be supplied*)
With Reference to Fitting Instructions – Electrical Connections

FITTING THE WIPER BLADE

The wiper blades should be changed every 12 months but this is dependent on use and operating conditions

With reference to the Maintenance Table and the Troubleshooting Table – Continued

Figure – Blade Clip Fixings

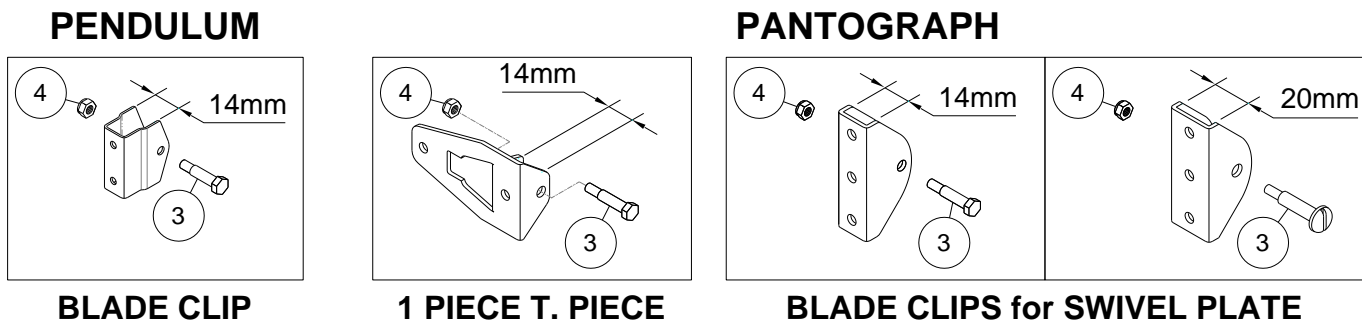

Ref Figure – Blade Clip Fixings

1. Remove blade retaining screw (1), and M4 Nylock nut (2), from blade clip on arm.

NOTE

No plastic spacers required – if supplied with blade

If only one end of the wiper blade rubber is captive, it must be fitted so it will be at the top of the screen when the arm is in the vertical position.

(Articulated blades only)

Ref Figure – Blade Captive End

2. Place wiper blade directly into arm blade clip.
3. Ensure that all fixing holes align, on wiper blade and arm blade clip.

Ref Figure – Blade Clip Fixings

4. Secure in place with blade retaining screw (1), and M4 Nylock nut (2).

IMPORTANT

DO NOT over tighten blade retaining screw and nut, as blade is required to pivot on glass.

Ref Figure – Nut Tightening

5. Secure nut until tight – then 1/4 turn back

Figure – Blade Captive End
Must be at top

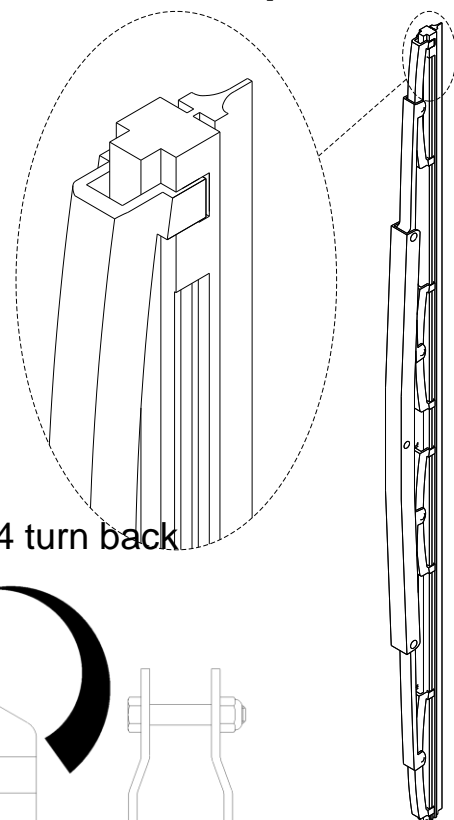
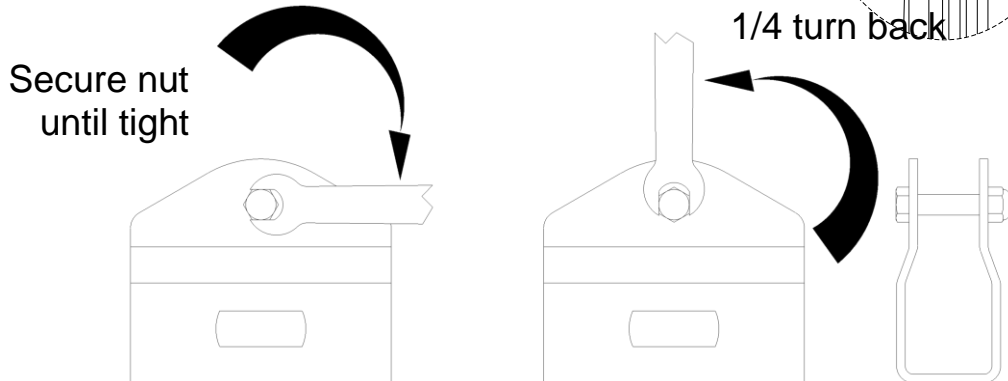

Figure - Nut Tightening



NOTE

Pictorial representation only, May not be exact to supplied arm

FITTING THE WIPER ARM ASSEMBLY

IMPORTANT:

The blade must be fitted to arm prior to arm being fitted. (This is to prevent blade clip damaging screen)

1. **Internally** – Run motor to insure it is parked correctly. Disconnect all electrical power.
2. **Externally** – While unit is being run, it is IMPORTANT to observe direction drive spindle rotates in immediately before it stops. This direction will give PARK POSITION.

Pantograph Arms Only:

Ref Figure – Arm Alignment

3. Fit arm onto spindle allowing blade to lay approx 50-75mm from edge of glass in PARKED POSITION. Test on a wet screen to prove clearance is acceptable.

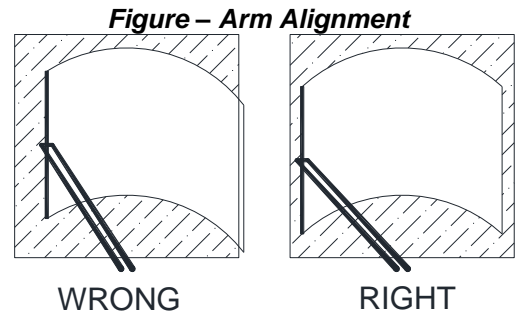

Ref Figure – Arm Fittings

4. Fit one 8mm flat washer (14) on to spindle next to arm head, then one M8 Nylock nut (15), on to each spindle.
5. Only tighten nut sufficiently to allow arm and blade to travel across glass when motor is run to see if positioning is correct.
6. If incorrectly positioned – DO NOT ATTEMPT TO ROTATE OR TWIST ARM ON SPINDLE this will damage splined end of drive spindle, resulting in arm and blade slipping in operation.

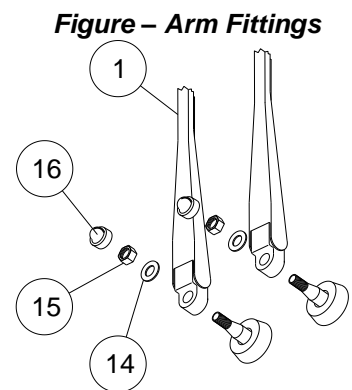

Ref Figure – Arm Extractor

7. To correct alignment errors, – loosen nut and gently pull arm up spindle, realign and repeat stages above.
Use arm extractor tool to help pull wiper arm up spindle, if required
8. When correctly aligned, tighten M8 spindle nuts
Torque M8 = 20Nm (on Spindle Nut)
9. Fit weather caps supplied with linkage (16)
10. Carefully push black wash hose attached to wiper arm onto bulkhead connector (**Not Supplied**)

IMPORTANT

On first fitting check spring pressure on blade in parked position it must NOT exceed recommended pressure

1-1.5kg

Pendulum Arms Only:

Ref Figure – Arm Fittings

3. Fit arm onto spindle allowing blade to lay approx 50-75mm from edge of glass in PARKED POSITION. Test on a wet screen to prove clearance is acceptable.

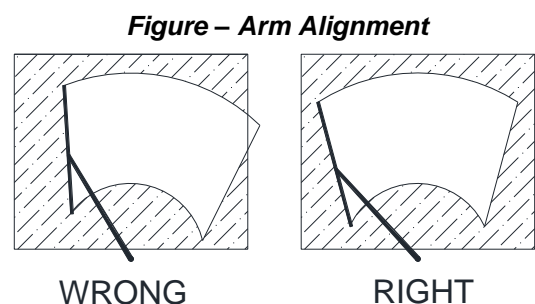

Ref Figure – Arm Fittings

4. Fit one 8mm flat washer (14) on to spindle next to arm head, then one M8 Nylock nut (15), on to each spindle.
5. Only tighten nut sufficiently to allow arm and blade to travel across glass when motor is run to see if positioning is correct.
6. If incorrectly positioned – DO NOT ATTEMPT TO ROTATE OR TWIST ARM ON SPINDLE this will damage splined end of drive spindle, resulting in arm and blade slipping in operation.

Figure – Arm Fittings

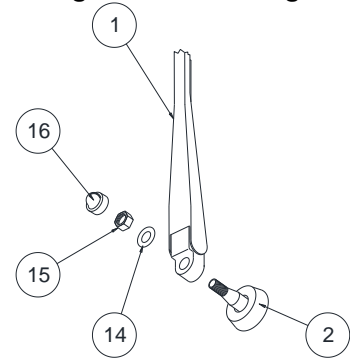

Ref Figure – Arm Extractor

7. To correct alignment errors, – loosen nut and gently pull arm up spindle, realign and repeat stages above.
Use arm extractor tool to help pull wiper arm up spindle, if required
8. When correctly aligned, tighten M8 spindle nuts
Torque M8 = 20Nm (on Spindle Nut)
9. Fit weather caps supplied with linkage (16)
10. Carefully push black wash hose attached to wiper arm onto bulkhead connector (**Not Supplied**)

IMPORTANT

On first fitting check spring pressure on blade in parked position it must NOT exceed recommended pressure
1-1.5kg

Figure – Arm Extractor

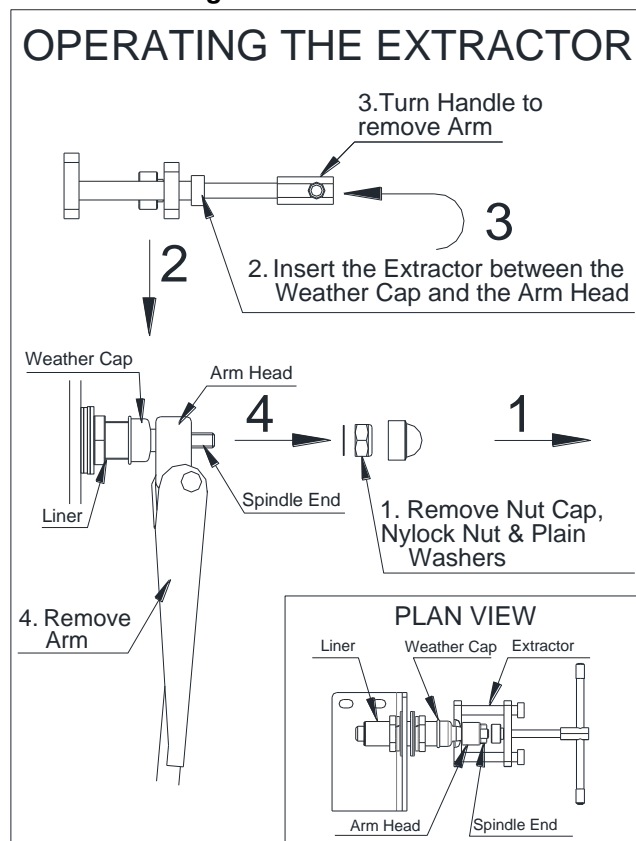

VARI ARC UNITS – ARC ADJUSTMENT

IMPORTANT

Vari-arc levers which have been factory set will be torqued and paint marked. Do not adjust. Unpainted lever nuts must be torque tightened M8 = 20Nm, prior to the unit being fitted.

1. **Internally** – Run motor to ensure it is parked correctly. Disconnect all electrical power.
2. Slacken securing Nylock nut (26) on vari arc lever.
3. Slide double bearing pivot pin (27) towards liner/spindle assembly to INCREASE arc to 90° max or away from liner/spindle assembly to DECREASE arc to 40° min.
4. Ensure you note markings on lever when correct arc is reached. important: pantograph systems must not exceed 90° arc of wipe
5. Tighten securing Nylock nut (26) on vari arc lever
Torque M8 = 20Nm (on Arm – V.A. lever)

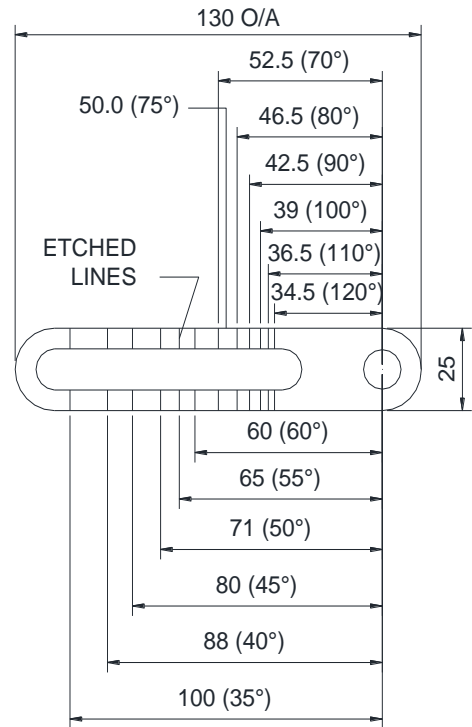
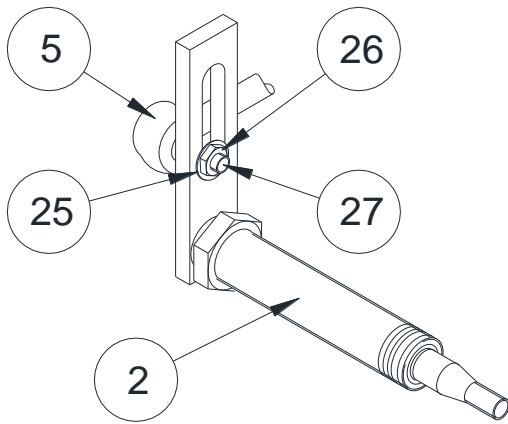

ITEM	DESCRIPTION	QTY
2	Liner V.Arc Lever Sub Assy	1
5	Double Bearing – 124 Crs	1
25	8mm Washer – Flat	1
26	M8 Securing Nylock Nut	1
27	V.Arc Bearing Pivot Pin	1

ADJUSTING THE WIPER BLADE ANGLE

Figure – Adjusting the Wiper Blade Angle

ENLARGED SCRAP VIEW
OF FITTINGS

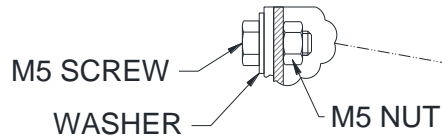

NOTE
PICTORIAL REPRESENTATION ONLY
TO SHOW HOW TO ADJUST FITTINGS
MAY NOT BE EXACT TO SUPPLIED ARM

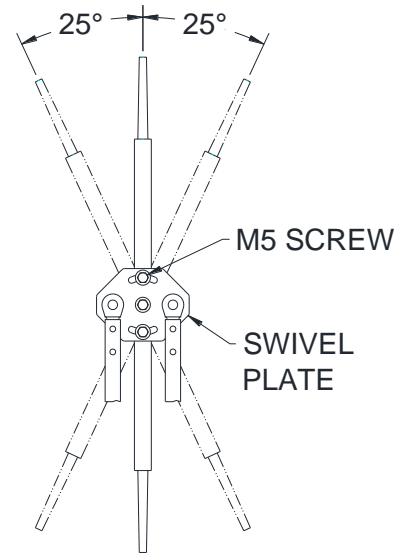
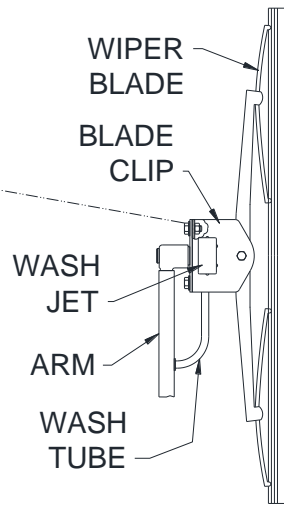

IMPORTANT

Adjusting the Wiper Blade Angle only applies to Pantograph Arms with a Swivel Plate

Ref Figure – Adjusting the Wiper Blade Angle

1. On back of adjustable swivel plate, slacken all M5 screw and nut assemblies to allow movement of blade clip on plate.
2. Rotate blade clip and blade to correct angle. Max 25° about centre.
3. Re-tighten all M5 screw and nut assemblies

Torque M5 = 4.5Nm (on Arm – Swivel Plate/Blade Clip)

TROUBLESHOOTING

Introduction

The following provides all the instructions and information necessary to locate problems and conduct tests on the windscreen wiper system components. The trouble-shooting tables provide for logical isolation of faults.

Safety Precautions

Always disconnect the power when servicing the Windscreen Wiper System, or on any ancillary components. Serious damage to the Equipment and/or Personal Injury may occur if the power is not disconnected.

Troubleshooting Procedures

Typical windshield wiper system troubleshooting procedures are contained in the Tables. These troubleshooting and repair procedures should be followed when encountering operational problems with the windshield wiper system

Troubleshooting Table

SYMPTOM	PROBABLE CAUSE	TESTS AND CHECKS	CORRECTIVE ACTION
Wiper motor fails to start	On/off switch Voltage Level System Jammed Defective wiper motor	Check position of switch Check supply voltage to switch. Check wiring and switch connections Check wiper linkage	Turn switch to on position Replace switch. Correct loose wiring connections. Replace broken wires Release linkage. Release wiper arm Replace motor
Motor shaft turns but linkage & arm remain static	Defective or loose drive crank	Check linkage for a loose drive crank	Secure or replace drive crank. Clean motor output shaft with wire brush before replacing. With Ref to Maintenance Table – continued for Torque settings.
System operates but wiper arm remains static	Wiper arm	Check for loose wiper arm connection onto drive spindle	Secure or replace wiper arm after cleaning spindle spline with wire brush. Torque to M8 = 20Nm
Erratic Motor	Voltage level Switch Wiring	Check supply voltage to wiper system Check for loose or broken wires	Correct voltage supply problem Replace faulty switch Repair or replace wiring up to motor. Replace motor if this wiring is damaged

Troubleshooting Table – Continued

SYMPTOM	PROBABLE CAUSE	TESTS AND CHECKS	CORRECTIVE ACTION
Slow Motor Operation	Voltage Level Switch Motor Bracket Linkage Defective Wiper Motor	Check supply voltage to wiper system Check for broken bracket Check to see if Linkage is free moving	Correct voltage supply problem Replace faulty switch Replace defective bracket Free linkage replace worn or damaged components Replace Wiper Motor
Arm and blade not operating correctly or over sweep operation	Voltage level Linkage Spindle Arm Blade	Check supply voltage to wiper system. Check for worn or broken linkage Check for excessive wear in spindle Check that arm is not loose on spindle Check for excessive wear on arm Check fixing for wear Check blade for wear Check for excessive smearing on screen	Correct voltage supply problem Replace linkage Replace spindle Re-tighten spindle Clean spline on spindles with wire brush. replace arm Replace blade Replace blade Replace blade
Excessive wear on blade.	Spring pressure.	Use spring balance on centre of blade clip till blade begins to lift off glass. 1.0 – 1.1/2 kg Must not exceed 2.0 kg	Replace spring/arm.
Washer system not working correctly	No washer fluid from jets	Check washer fluid level in tank Check for damage to tank Check Pump is operational	Fill tank (see Note) Replace tank (see Note) Replace pump if faulty (see Note)

NOTE

Tank and / or Pump may not be supplied by Hepworth's, but we recommend checking of these items in any case as lack of washer fluid on screen may lead to damage or premature failure of Windscreen Wiper equipment

MAINTENANCE – TABLE

Introduction

The following contains all preventative maintenance details for the windscreen wiper components. Preventative maintenance procedures include the information required for when to replace the wiper blades.

Refer to the Maintenance Instructions Section for removal and replacement for procedures.

Safety Precautions

Always disconnect the power when servicing the Windscreen Wiper System, or on any ancillary components. Serious damage to the Equipment and/or Personal Injury may occur if the power is not disconnected.

Scheduled Maintenance Action Check

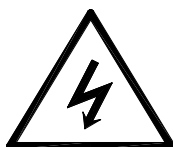

WARNING:

Isolate the electrical supply before commencing any fitting work on any part of the wiper system.

The Maintenance Table is a Scheduled Maintenance Action Index. The index provides a list of all performance tests if applicable and preventative maintenance procedures. The table has three columns: Periodicity, Equipment and Task

The Periodicity column indicates the intervals between the maintenance tests and preventative maintenance procedures.

The equipment column lists the equipment, assembly or subassembly that corresponds to the maintenance action.

The task column lists the maintenance task to be performed.

Maintenance Table

<i>PERIODICITY</i>	<i>EQUIPMENT</i>	<i>TASK</i>
Daily	Wiper Blades	Inspect wiper blades for damage, torn or missing rubber blades. Replace wiper blades as required
Daily	Windscreen Wiper System	Perform function test of wiper washer system. Do not carry out function test on a dry screen
Daily	Wash Tank	Ensure wash tank is filled with washer fluid to prevent wipers being used on a dry screen
Yearly or as required	Wiper blades	Non serviceable item. Replace at overhaul period or as required.

Maintenance Table – continued

IMPORTANT

Where internal fixing screws and/or nuts are factory set and paint marked, leave untouched unless required to be changed or paint mark is damaged.

PERIODICITY	EQUIPMENT	TASK
Six Monthly	Complete System	<p>Check all torque settings for complete wiper system: Ref Note above. Shown below are torque settings used. (If required – Set torque wrench to correct setting. Fit on nut, turn, if correct, wrench should click.)</p> <p>M5 = 4.5Nm <i>(on Arm Swivel Plate/Blade Clip – Nut)</i></p> <p>M8 = 2Nm <i>(on Nylon Bulkhead Connector – Nut)</i> M8 = 20Nm <i>(on SS Bulkhead Connector – Nut)</i></p> <p>M6 = 12Nm <i>(on Motor Bolts)</i> M6 = 18Nm <i>(on Splined Drive Crk, Nut & Bolt)</i> M8 = 16Nm <i>(on Coned Drive Crk, Motor Shaft)</i> M8 = 20Nm <i>(on Spindle Nut & V.A. Lever)</i> M20 = 25Nm <i>(on Liner – Metal Bulkhead)</i></p> <p>3/8" = 15Nm <i>(on Tie Bar with Threadlock)(If fitted)</i></p> <p>Carry out a visual check for wear in rod end. (Pull on the tie-bar/double bearing to see if any movement in the rod end bearing at the inner ball on the outer casing.)</p>

How to check for wear on the Rod End

Ref Figure – Rod End Bearing

1. Pull on tie-bar or double bearing to see if any movement in rod end bearing at inner ball on outer casing.

In accordance with Maintenance Table – continued. Carry out a visual check for wear in rod end.

2. If excessive movement – replace

Figure - Rod End Bearing

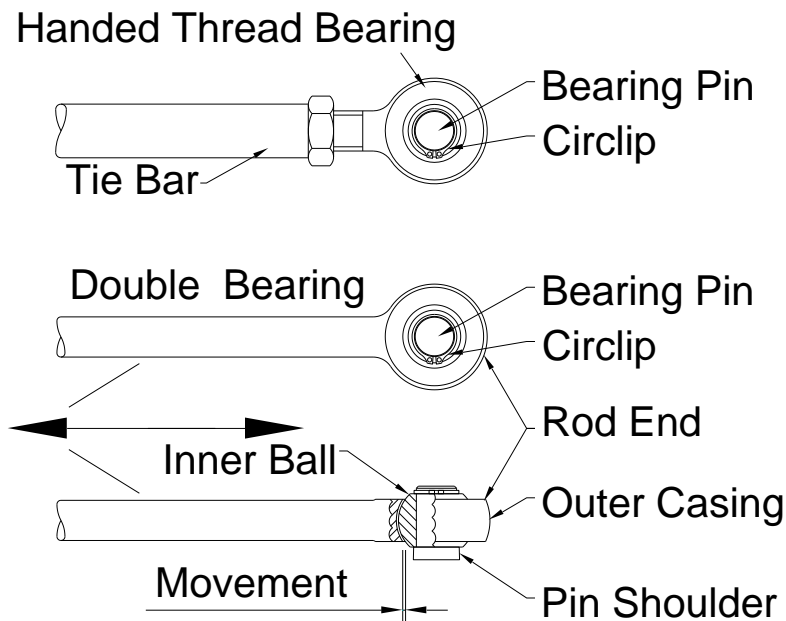

MAINTENANCE INSTRUCTIONS

NOTE

Retain all items removed in a safe place, as they will be required on reassembly.

Any item to be discarded must be done in accordance to vessels described task guidelines

If you experience any difficulty in the removal/replacement of any of the units/components, please do not hesitate to contact Customer Service at B. Hepworth & Co. for advice.

Use the drawings for reference.

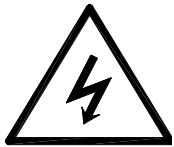

WARNING:

Isolate the electrical supply before commencing any fitting work on any part of the wiper system.

TO REPLACE THE WIPER BLADE

The wiper blades should be changed every 12 months but this is dependent on use and operating conditions

With reference to the Maintenance Table and the Troubleshooting Table – Continued

Removal

1. **Internally** – Run motor to ensure it is parked correctly. Disconnect all electrical power.
2. **Externally** – Carefully pull wiper arm assembly away from windscreen to enable access to wiper blade.

Figure – Blade Clip Fixings

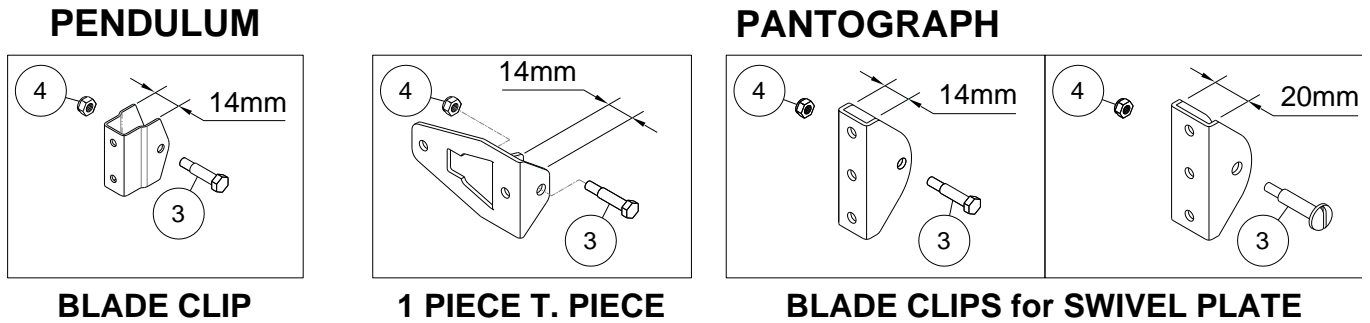

Ref Figure – Blade Fittings

3. Remove one blade retaining screw (3), and one M4 Nylock nut (4), from blade clip on arm.
4. Remove wiper blade from blade clip on wiper arm.

Reassembly

NOTE

Note if only one end of blade rubber captive, it must be at top of screen

1. Place wiper blade into blade clip on wiper arm.

Ref Figure – Blade Captive End

2. Ensure that all fixing holes align.
3. Secure in place with blade retaining screw (3), and nut (4).

IMPORTANT

Do not over tighten blade screw and nut, as wiper blade is required to pivot on glass.

Ref Figure – Nut Tightening

4. Secure nut until tight – then 1/4 turn back

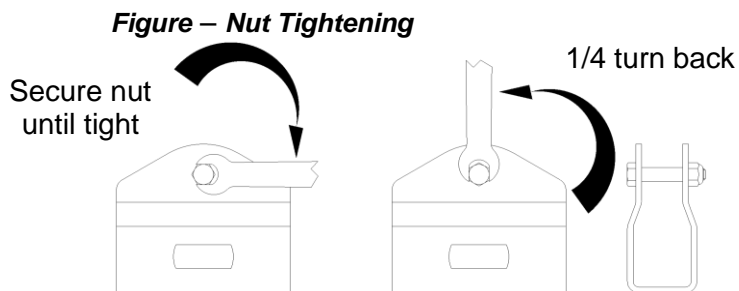
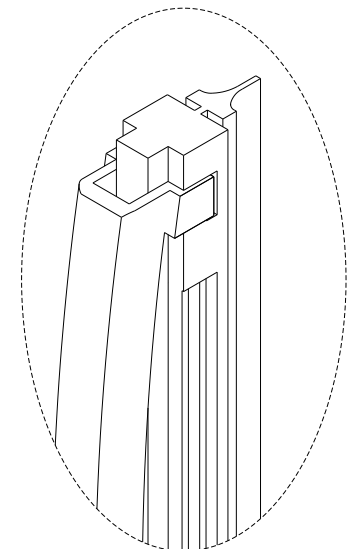

Figure – Blade Captive End



5. Lower wiper blade carefully back onto windscreen.

TO REPLACE THE WIPER ARM

Removal

With Reference to Wiper Arm Assembly – Pantograph or Pendulum

1. ***Internally*** – Run motor to ensure it is parked correctly. Disconnect all electrical power.
2. ***Externally*** – While Unit is being run it is IMPORTANT to observe direction drive spindle rotates in, immediately before it stops. This direction will give PARK POSITION.
3. Remove 8mm Nut Cap(s) – (16), M8 Nylock Nut(s) – (15) and 8mm Flat Washer(s) – (14). Then using Arm Extraction Tool carefully remove Arm
(Arm Extractor Tool is available see Fitting the Wiper Arm Assembly for instructions)

Replacement

IMPORTANT:

The Blade must be fitted to the Arm prior to the Arm being fitted. (This is to prevent the Blade Clip damaging the screen,)

1. Fit wiper arm
In accordance with Fitting the Wiper Arm Assembly

TO REPLACE THE 24V DRIVE CRANK/DOUBLE BEARING ASSEMBLY

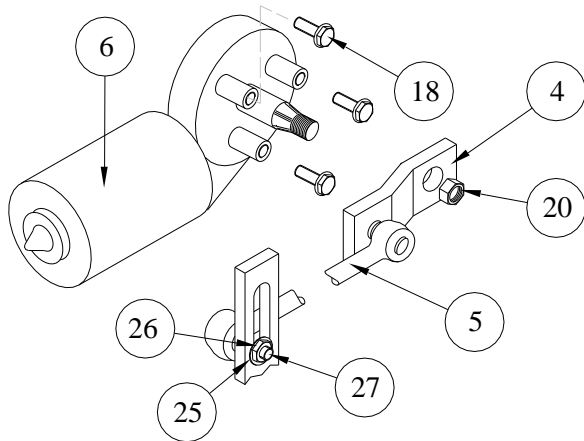

Figure – 24v Units

ITEM	DESCRIPTION	QTY
4	Drive Crank Sub Assy 30 Crs	1
5	Double Bearing – 124 Crs	1
6	30Nm (IER) Motor	1
18	M6 Fixing Bolts	3
20	M8 Securing Nut	1
25	8mm Washer – Flat	1
26	M8 Securing Nylock Nut	1
27	V.Arc Bearing Pivot Pin	1

Removal

Ref Figure – 24v Units

1. **Internally** – Run motor to ensure it is parked correctly. Disconnect all electrical power.

IMPORTANT:

Please make a note of Drive Crank POSITION relative to SPINDLE LEVER, as this will affect PARK position for ARMS and BLADES, i.e. SPINDLE LEVER facing towards Motor or away from Motor

Make a note of Vari Arc Pin/Double Bearing position on Vari Arc Lever.

2. On Vari Arc Lever, unscrew M8 Securing Nylock Nut – (26). Remove it and Washer – (25). Slide out V.Arc Bearing Pivot Pin – (27) complete with Double Bearing – (5)
3. Unscrew Drive Crank Nut – (20) carefully remove Drive Crank/Double Bearing Assy – (4), from Motor Drive Shaft.

Replacement

1. **From Inside Unit** – Carefully fit Drive Crank/Double Bearing Assy – (4), over Motor Drive Shaft, (refer to the Note after operation 1 on ‘Removal’ for position.)
2. Fit V.Arc Bearing Pivot Pin – (27) complete with Double Bearing – (5) through Vari Arc Lever. Replacing in same hole position (refer to the Note before operation 2 on ‘Removal’ for position.) for correct setting of arc on replacement
3. Tighten Drive Crank Nut – (20).

TO REPLACE THE 12V DRIVE CRANK/DOUBLE BEARING ASSEMBLY

Figure – 12v Units

ITEM	DESCRIPTION	QTY
4	Drive Crank Sub Assy 30 Crs	1
5	Double Bearing – 124 Crs	1
6	30Nm (IER) Motor	1
18	M6 Fixing Bolts	3
19	M8 Securing Bolt	1
20	M8 Securing Nylock Nut	1
25	8mm Washer – Flat	1
26	M8 Securing Nylock Nut	1
27	V.Arc Bearing Pivot Pin	1

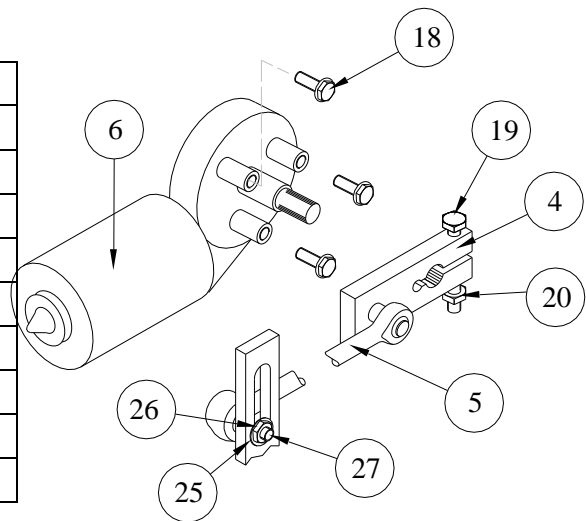

Removal

Ref Figure – 12v Units

1. **Internally** – Run motor to ensure it is parked correctly. Disconnect all electrical power.

IMPORTANT

Please make a note of Drive Crank POSITION relative to SPINDLE LEVER, as this will affect PARK position for ARMS and BLADES, i.e. SPINDLE LEVER facing towards Motor or away from Motor

Make a note of Vari Arc Pin/Double Bearing position on Vari Arc Lever.

2. On Vari Arc Lever, unscrew M8 Securing Nylock Nut – (26). Remove it and Washer – (25). Slide out V.Arc Bearing Pivot Pin – (27) complete with Double Bearing – (5)
3. Unscrew Drive Crank Nut – (20) carefully remove Drive Crank/Double Bearing Assy – (4), from Motor Drive Shaft.

Replacement

1. **From Inside Unit** – Carefully fit Drive Crank/Double Bearing Assy – (4), over Motor Drive Shaft, (refer to the Note after operation 1 on ‘Removal’ for position.)
2. Fit V.Arc Bearing Pivot Pin – (27) complete with Double Bearing – (5) through Vari Arc Lever. Replacing in same hole position (refer to the Note before operation 2 on ‘Removal’ for position.) for correct setting of arc on replacement
3. Tighten Drive Crank Nut – (20).

TO REPLACE THE LEVER/LINER/SPINDLE SUB ASSEMBLY

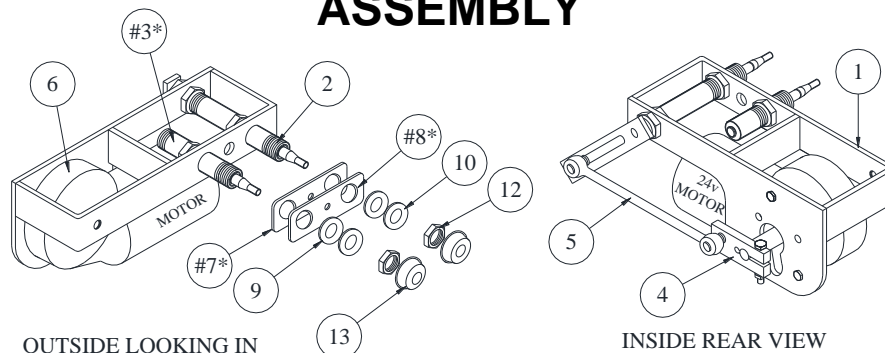

ITEM	DESCRIPTION	QTY
1	Motor Mounting Bracket	1
2	Liner V.Arc Lever Sub Assy	1
#3*	Idler Liner Sub Assy (Panto Only)	1
4	Drive Crank Sub Assy 30 Crs	1
5	Double Bearing - 124 Crs	1
6	30Nm (IER) Motor	1

ITEM	DESCRIPTION	QTY	QTY
		PANTO	PEND
#7*	Idler Gasket (Panto Only)	1	--
#8*	Idler Plate (Panto Only)	1	--
9	20mm Washer - Neoprene	2	1
10	20mm Washer – Flat	2	1
12	M20 Hex. Nut	2	1
13	20mm Weather Cap	2	1

Removal

- Internally** – Run motor to insure it is parked correctly. Disconnect all electrical power. Disconnect wiring from Motor.
- Remove entire wiper motor assy.
IMPORTANT:
Please make a note of Drive Crank POSITION relative to SPINDLE LEVER, as this will affect PARK position for ARMS and BLADES, i.e. SPINDLE LEVER facing towards Motor or away from Motor
- Slacken both bearing nuts at either end of tie bar.
IMPORTANT:
Make a note of the protrusion length of the Liner and/or Spindle from the front of the Bracket (1).
- Unscrew tie bar from right hand bearing of liner/lever/bearing assy.
- Unscrew remove entire liner/lever/bearing assy from bracket.

Replacement

- Screw entire **new** liner/lever/bearing assy into bracket.
- Screw tie bar onto right hand bearing at main liner/lever/bearing assy.
- Tighten both bearing nuts at either end of tie bar.

IMPORTANT:

Ensure bearing centres are as stated in drawing (figure 1)

- Replace entire wiper motor assy.
In accordance with Fitting the Wiper Motor Assy
- Fit wiper arm assy.
In accordance with Fitting the Wiper Arm Assy

CONTROLLER INSTALLATION INSTRUCTIONS

NOTE

Retain all items removed in a safe place, as they will be required on reassembly.

Any item to be discarded must be done in accordance to vessels manufacturer described task guidelines

If you experience any difficulty in the fitting of any of the controller /switches, please do not hesitate to contact Customer Service at B. Hepworth & Co. for advice.

Use the drawings for reference.

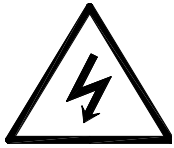

WARNING:

Isolate the electrical supply before commencing any fitting work on any part of the wiper system.

12V/24V TOGGLE SWITCH – WIRING & SIZES

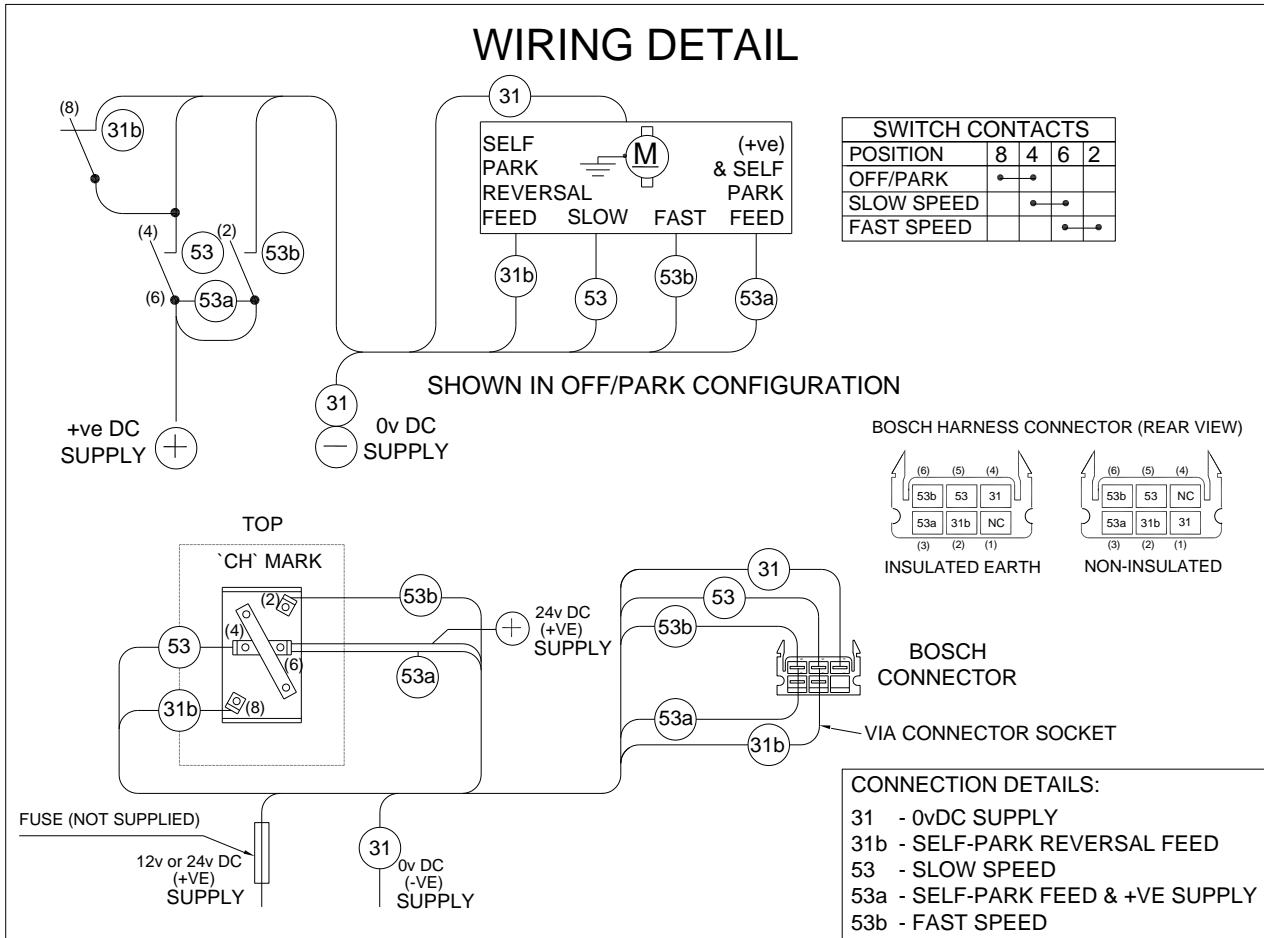

CONSOLE CUT OUT DETAIL - 90041400 - 1 x 12/24v Toggle Switch & Plate

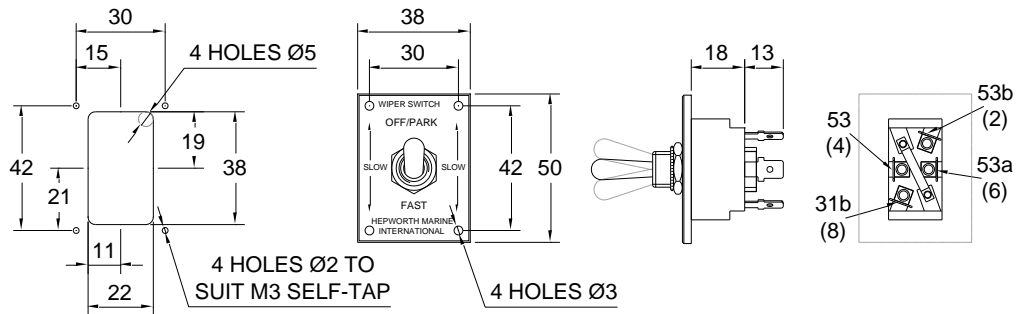

CONSOLE CUT OUT DETAIL - 10079200 - 1 x 12/24v Toggle Switch only

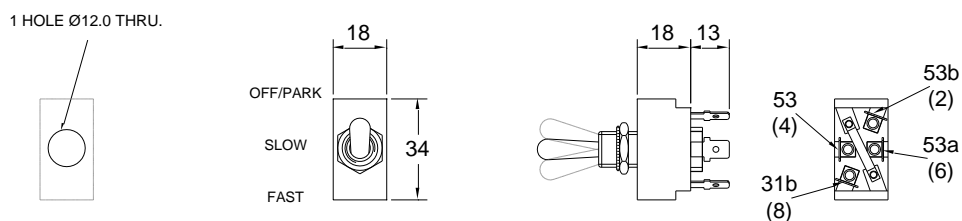

12V/24V TOGGLE SWITCH – OPERATION

NOTE

For other all other switch or control instructions refer to the ship's fitters/suppliers manual.

Ref Figure – Toggle Switch

1. Check switch is in off position before starting. **(OFF/PARK)**

IMPORTANT

Do not run wipers on a dry screen.

2. This switch does not control application of washer fluid.
3. Pushing toggle to centre position **(SLOW)** gives a continuous wipe across screen at a standard speed, with no delay between wipes.
4. Pushing toggle to bottom position **(FAST)** gives a continuous wipe across screen at a faster speed, with no delay between wipes.
5. Push toggle to top position when finished. **(OFF/PARK)**

Figure - Toggle Switch

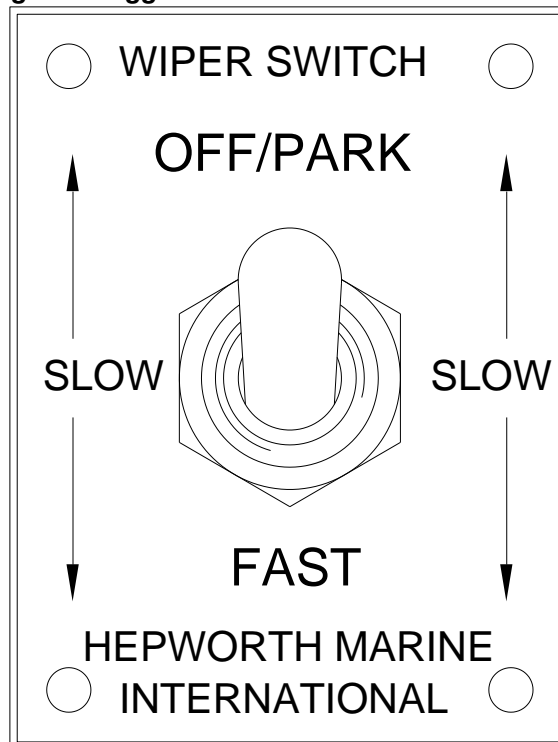

12V/24V ROTARY SWITCH – WIRING & SIZES

WIRING DETAIL

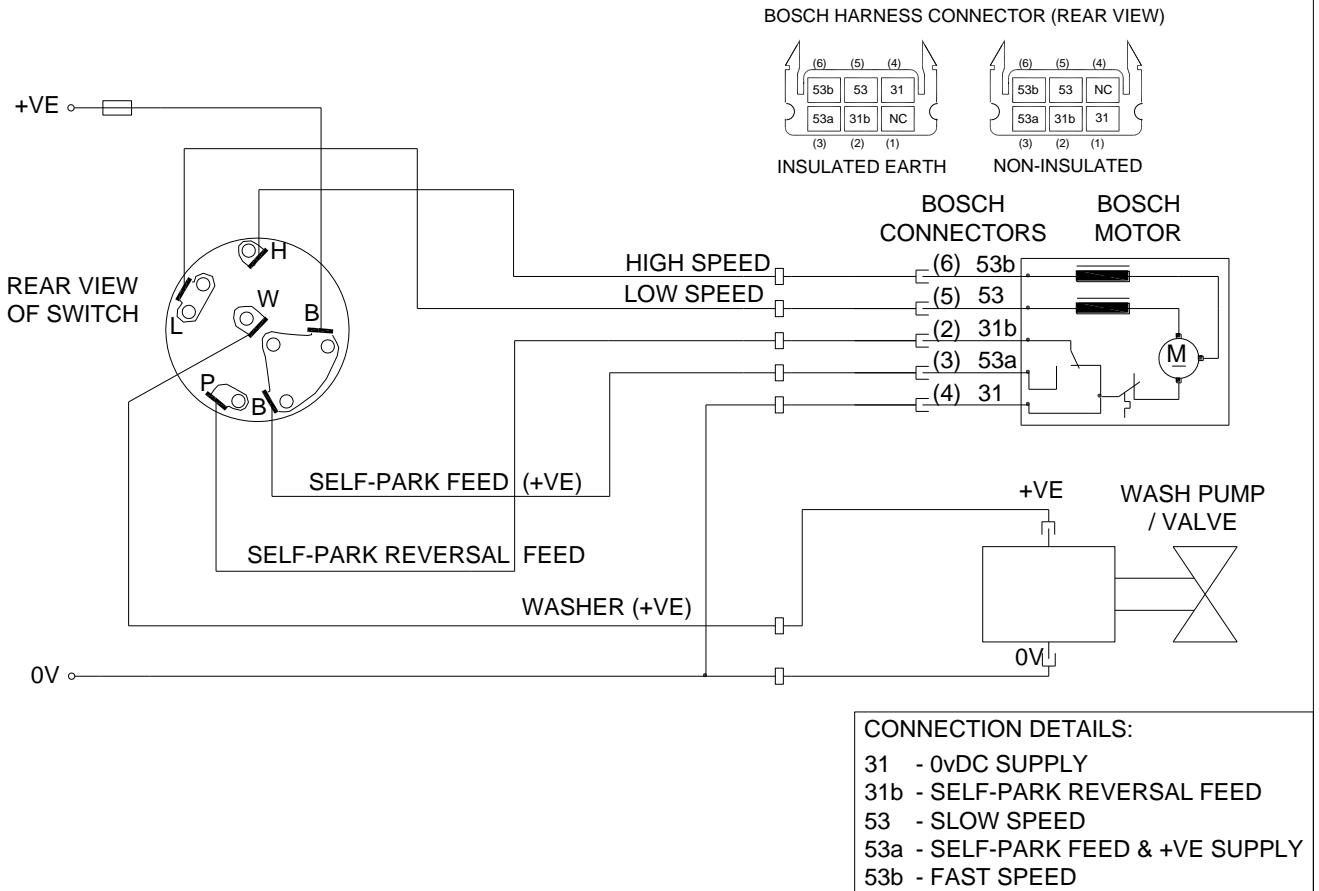

CONSOLE CUT OUT DETAIL - 90043000 - 1 x 12/24v Rotary Switch & Plate

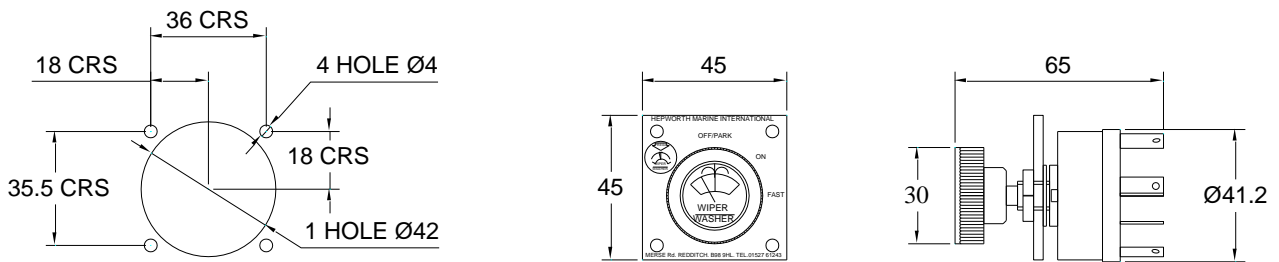

CONSOLE CUT OUT DETAIL - 10094800 - 1 x 12/24v Rotary Switch only

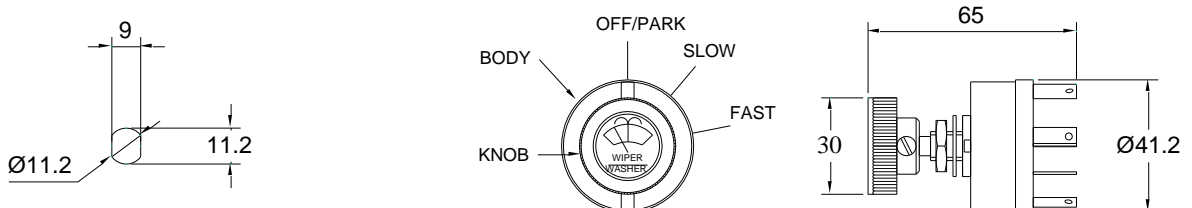

12V/24V ROTARY SWITCH – OPERATION

NOTE

For other all other switch or control instructions refer to the ship's fitters/suppliers manual.

Ref Figure – Rotary Switch

1. Check switch is in off position before starting. **(OFF/PARK)**

IMPORTANT

Do not run wipers on a dry screen.

2. To apply washer fluid to screen, press knob. **(WIPER WASHER)** This will apply washer fluid for period of time button is pressed.

NOTE

It does not activate the wiper

3. Turn knob CLOCKWISE it will (CLICK) which turns wipers on, **(ON)**. This setting gives a continuous wipe across screen at a standard speed, with no delay between wipes.
4. Turn knob CLOCKWISE to last (CLICK) **(FAST)**. This setting gives a continuous wipe across screen at a faster speed, with no delay between wipes.
5. Turn knob ANTI-CLOCKWISE to off position when finished. **(OFF/PARK)**

Figure – Rotary Switch

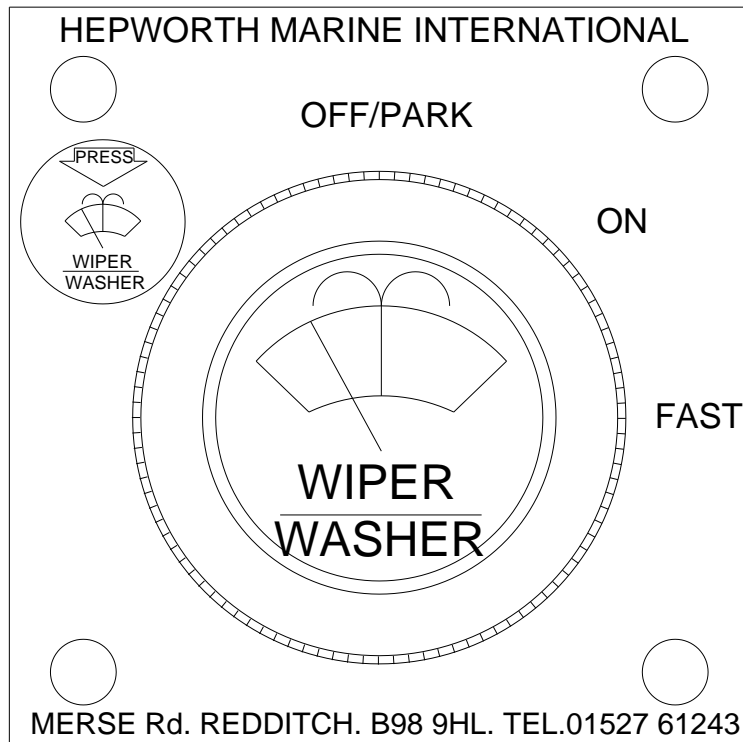

12V OR 24V MULTI-SWITCH – WIRING & SIZES

WIRING DETAIL

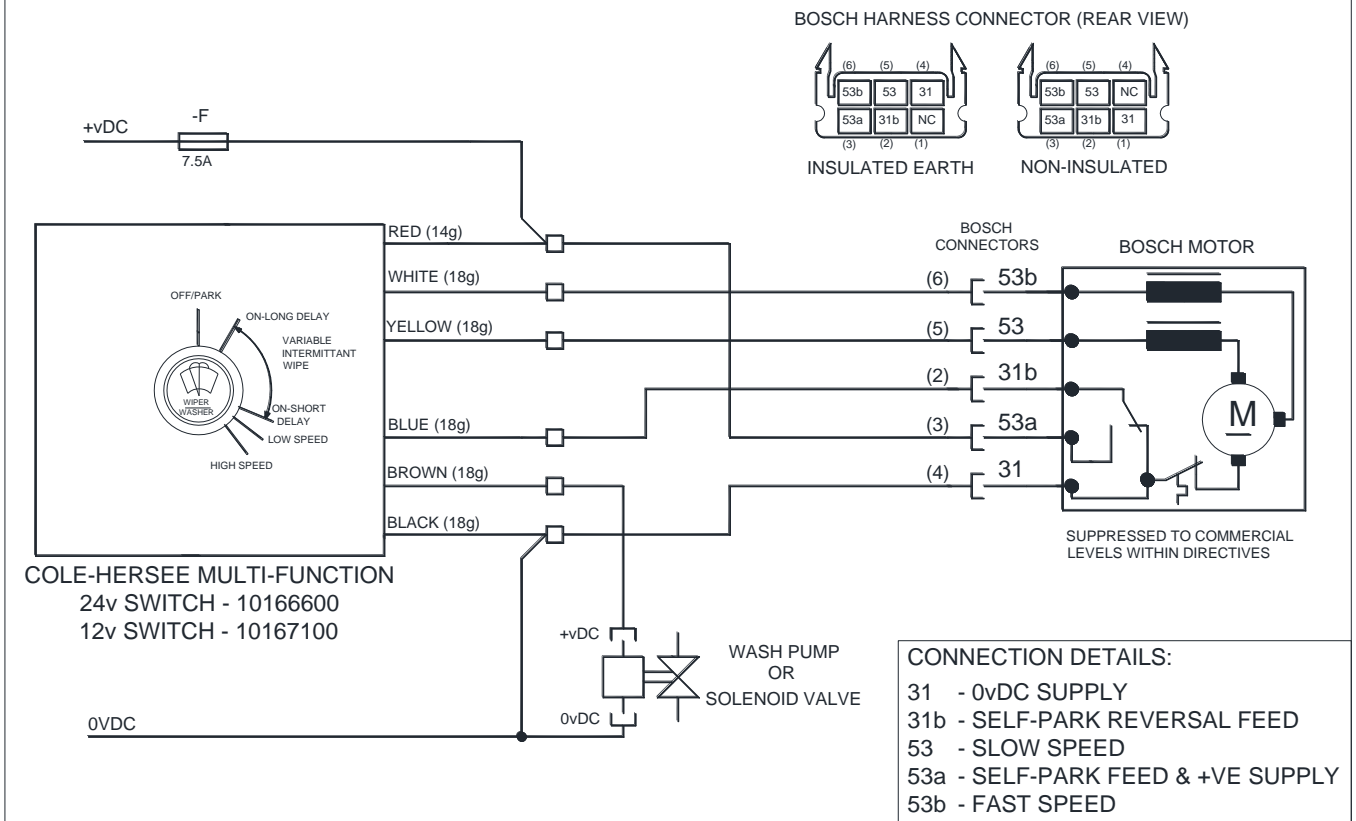

CONSOLE CUT OUT DETAIL - 90087010 - 1 x 24v Multi-Switch & Plate - 90087200 - 1 x 12v Multi-Switch & Plate

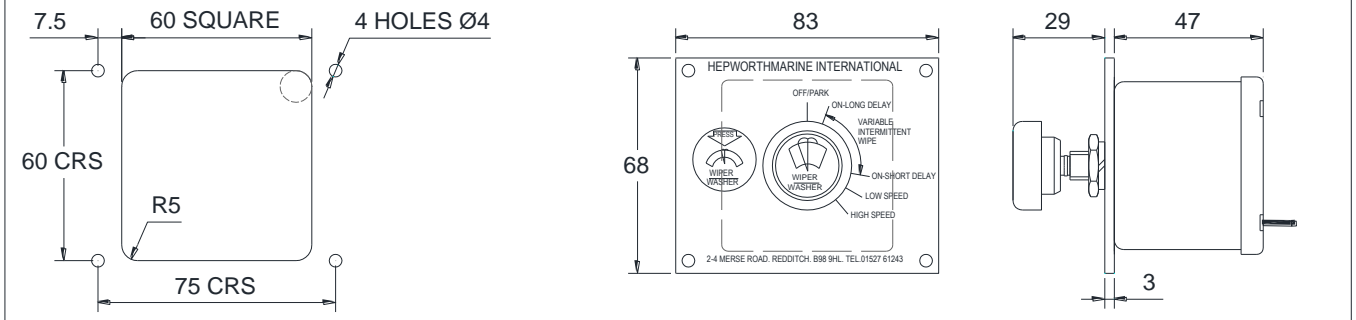

CONSOLE CUT OUT DETAIL - 10166600 - 1 x 24v Multi-Switch only - 10167100 - 1 x 12v Multi-Switch only

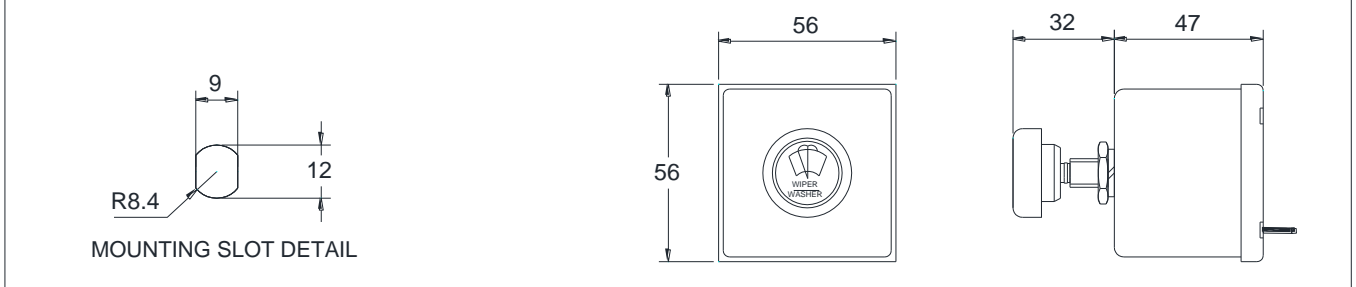

12V OR 24V MULTI-SWITCH – OPERATION

NOTE

For other all other switch or control instructions refer to the ship's fitters/suppliers manual.
Ref Figure – Multi-Switch

1. Check switch is in off position before starting. **(OFF/PARK)**

IMPORTANT

Do not run wipers on a dry screen.

2. To apply washer fluid to screen, press knob. **(WIPER WASHER)** This will apply washer fluid for period of time button is pressed.

NOTE

The wiper will also operate for 3-4 wipes at normal speed after the washer fluid stops.

3. Turn knob **CLOCKWISE** it will (CLICK) which turns wipers on. Switch is now in area of variable intermittent wipe cycle time. Which is between **(ON-LONG DELAY 15 seconds)** and **(ON-SHORT DELAY 2 seconds)** positions.
4. As knob is turned further clockwise between two positions it shortens delay period between wipes.
5. Turn knob **CLOCKWISE** to next (CLICK) **(LOW SPEED)**. This gives a continuous wipe across screen at a standard speed, with no delay between wipes.
6. Turn knob **CLOCKWISE** to last (CLICK) **(HIGH SPEED)**. This gives a continuous wipe across screen at a faster speed, with no delay between wipes.
7. Turn knob **ANTI-CLOCKWISE** to off position when finished. **(OFF/PARK)**

IMPORTANT

When turning to the off position ensure that it CLICKS to confirm fully off

Figure – Multi-Switch

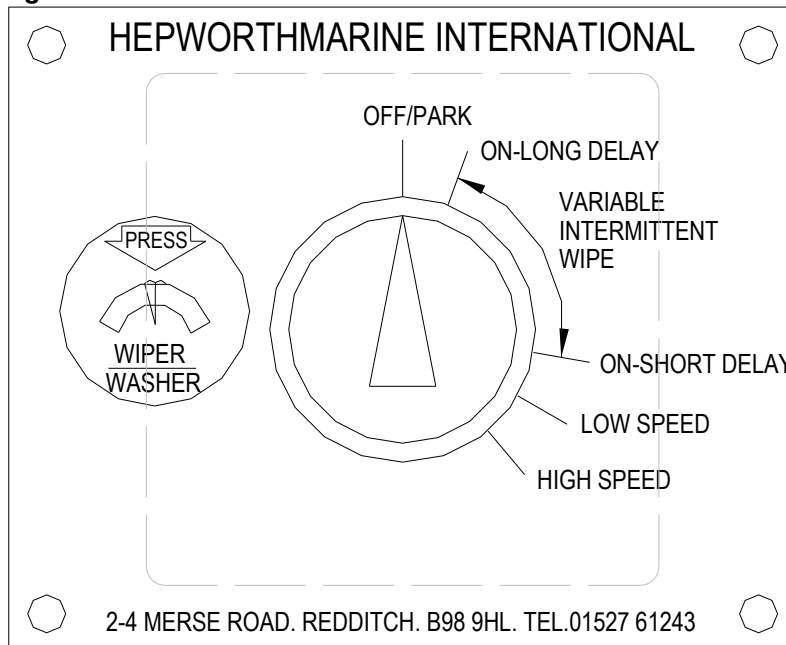

EXTERNAL FITTINGS – LINKAGE

Fittings for M20 Liner and 12mm Spindle protruding outside the Bulkhead – Pendulum

KIT - 65009701

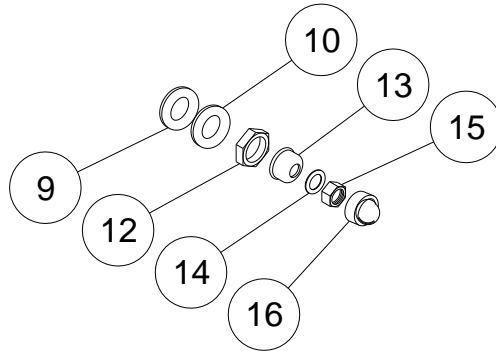

Part	Qty	No.	Description
65009701	30/50 External Fittings Kit – Pendulum		1 per unit
Consists of	1 each of items (9, 10, 12, 13, 14, 15 & 16)		

Fittings for M20 Liners and 12mm Spindles protruding outside the Bulkhead – Pantograph

KIT - 65009702

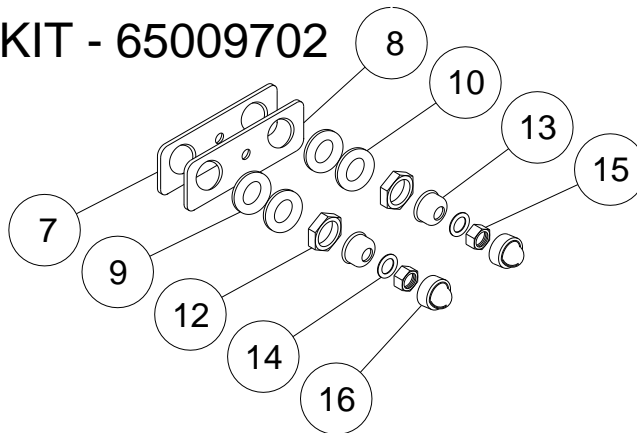

Part	Qty	No.	Description
65009702	30/50 External Fittings Kit – Pantograph		1 per unit
Consists of	1 each of items (7 & 8) plus 2 each of items (9, 10, 12, 13, 14, 15 & 16)		

Individual Item Part Numbers

Part No.	Description	Qty
60267900	Idler Gasket (7) (Pantograph Only)	1 per unit
60119600	Idler Plate (8) (Pantograph Only)	1 per unit
10020600	20mm Washer – Neoprene (9)	1 per liner
10024300	20mm Washer – Plain (10)	1 per liner
10011900	M20 Hex Nut (12)	1 per liner
60034600	20mm Weather Cap (13)	1 per liner
10022900	M8 Plain Washer (14)	1 per liner
10013900B	M8 Nylock Nut (15)	1 per liner
10060300	8mm Nut Cap (16)	1 per liner

EXTERNAL FITTINGS – ARM

Pendulum

Fittings for Arm and Blade – Pendulum

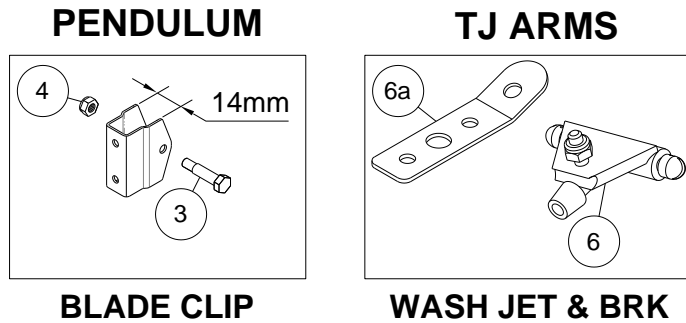

Part No.	Description	Qty
80204600	Blade Retaining Screw (14mm B. Clip) (3)	1 per arm
10011400	M4 Nylock Nut (4)	1 per arm
80200100	Wash Jet Assy (6)	1 per arm
80201700	Wash Jet Bracket (6a)	1 per arm
80200400	Wash Hose – 4mm I/D x 6Mmm O/D (7) (Not shown)	Metres

Pantograph

Fittings for Arm and Blade -Pantograph – Swivel Plate

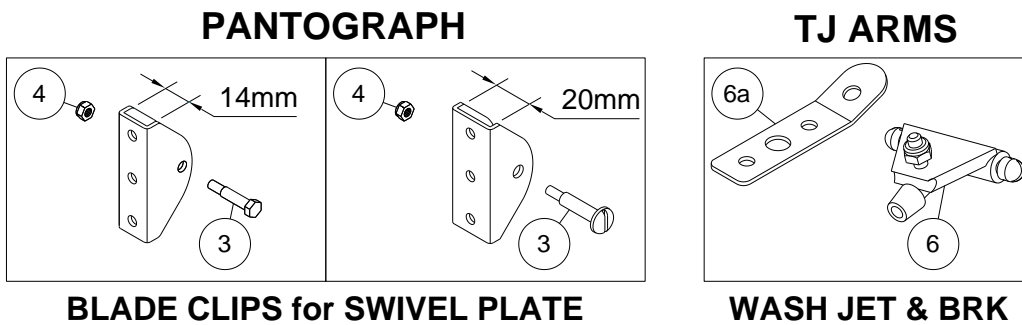

Part No.	Description	Qty
80205600	Blade Retaining Screw (14mm B. Clip) (3)	1 per arm
80010700	Blade Retaining Screw (20mm B. Clip) (3)	1 per arm
10011400	M4 Nylock Nut (4)	1 per arm
80200100	Wash Jet Assy (6)	1 per arm
80201700	Wash Jet Bracket (6a)	1 per arm
80200400	Wash Hose – 4mm I/D x 6Mmm O/D (7) (Not shown)	Metres

Fittings for Arm and Blade -Pantograph – 1 Piece T. Piece

PANTOGRAPH

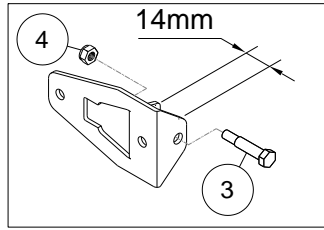

1 PIECE T. PIECE

TJ ARMS

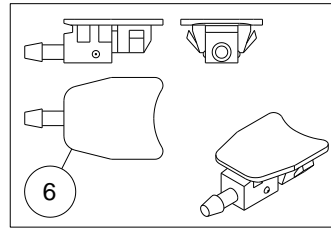

WASH JET

Part No.	Description	Qty
80205600	Blade Retaining Screw (14mm B. Clip) (3)	1 per arm
1. 10011400	M4 Nylock Nut (4)	1 per arm
15031100	Wash Jet Assy (6)	1 per arm
80200400	Wash Hose – 4mm I/D x 6Mmm O/D (7) (Not shown)	Metres

Arm Extractor Tool

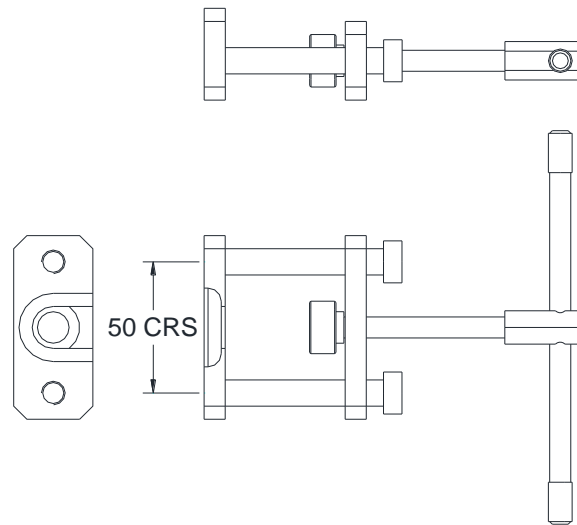

Part No.	Description	Qty
60680600	Arm Extractor Tool – All Head Types	as Required

THIS PAGE INTENTIONALLY LEFT BLANK

THIS PAGE INTENTIONALLY LEFT BLANK

North West Marine Distributors Ltd

26940 26th Avenue

Aldergrove, BC V4W 4A4, Canada

Phone: (604) 607-7901

Email: info@northwestmarine.ca.

www.northwestmarine.ca